

SIEMENS



Room Unit for Boiler Control

With OpenTherm Interface

User manual

QAA73.210

Edition 1.1
Device series A
CE1U2283en
2015-09-16

Building Technologies

Siemens Switzerland Ltd
Building Technologies Division
International Headquarters
Gubelstrasse 22
6301 Zug
Switzerland
Tel. +41 41-724 24 24
www.siemens.com/buildingtechnologies

© Siemens Switzerland Ltd, 2010
Subject to change

Table of contents

1	Overview	5
1.1	Features	5
1.2	Product liability	6
1.3	Disposal	6
2	Mounting and Installation.....	6
2.1	Engineering	6
2.2	Installation	7
2.3	Electrical installation	8
3	Commissioning.....	9
3.1	Operational faults.....	9
4	Handling.....	10
4.1	Operation.....	10
4.2	Programming room units parameters	15
4.2.1	User levels.....	15
4.2.2	Overview of settings.....	16
4.3	Programming Siemens BMU parameters	18
5	Description of room unit settings	19
5.1	Time and day (TIME)	19
5.2	Time switch program (TSPHC, TSPCC, TSPHW).....	19
5.2.1	Day selection	19
5.2.2	Switching times.....	20
5.3	Heating circuit (HEAT).....	20
5.4	Cooling circuit (COOL).....	27
5.5	Domestic hot water (DHW).....	27
5.6	Configuration (CONF).....	29
6	Functions	30
6.1	Types of compensation	30
6.1.1	Weather compensation	30
6.1.2	Weather compensation with room influence	30
6.1.3	Room compensation	31
6.1.4	Fix flow temperature setpoint	31
7	Dimensions	32
8	Technical data.....	33
Index	34

1 Overview

Brief description

The QAA73.210 is a digital multi-functional room unit for one or 1 heating circuits and d.h.w. control.

Boiler control delivers the outside temperature and other information to the QAA73.210 room unit via the OpenTherm communication interface. Based on the outside temperature, the room temperature and a number of other parameters, the interface calculates the required flow temperature setpoints for the heating circuits and transmits them to the boiler control. In addition, the d.h.w. temperature setpoint is transmitted to the boiler control.

The optimization functions offer energy savings without sacrificing comfort. The room sensor required for that purpose is integrated in the unit.

1.1 Features

Operating functions

- Operating sections (operating levels) based on ergonomic and functional considerations
- Clear assignment of basic functions:
- Operating mode, setpoint adjustment and occupancy button
- A number of actual values can be accessed via the Info button
- Additional functions can be programmed via programming mode
- Every setting or change is displayed and thus acknowledged
- Heating circuit program with up to 4 heating periods per day can be selected on an individual basis
- Cooling circuit program with up to 4 heating periods per day can be selected on an individual basis
- D.h.w. program with up to 4 heating periods per week can be selected on an individual basis
- Holiday function
- Special mode for setting the parameters of Siemens boiler control systems

Functions

- Weather-compensated flow temperature control while giving consideration to the building's thermal dynamics
- Weather-compensated flow temperature control with room compensation
- Pure room temperature control
- Effect of room temperature deviation can be adjusted
- ECO functions (24-hour limit switch, automatic summer / winter changeover)
- Room temperature switching differential for limiting the room temperature
- Adjustable maximum limitation of the flow temperature (especially in connection with floor heating systems)
- Frost protection for the building
- D.h.w. control with release and preselection of setpoint for the boiler controller
- Legionella function
- Integrated clock with a reserve of at least 12 hours

Other features

- Communication with the boiler control via OpenTherm interface
- Power supply via OpenTherm bus

1.2 Product liability

- The products may only be used in building services plant and applications as described above
- When using the products, all requirements specified under "Technical data" must be observed
- The local regulations for electrical installation must be complied with

1.3 Disposal



The device is classified as waste electronic equipment in terms of the European Directive 2002/96/EC (WEEE) and should not be disposed of as unsorted municipal waste.

The relevant national legal rules must be adhered to.
Regarding disposal, use the systems setup for collecting electronic waste.

Observe all local and applicable laws.

2 Mounting and Installation

2.1 Engineering

Mounting location

- In the main living room or reference room
- The place of installation should be chosen so that the sensor can capture the room temperature as accurately as possible, without being affected by direct solar radiation or other heating or cooling sources.
- Mounting height is about 1.5 meters above the floor
- The unit can be fitted to most commercially available recessed conduit boxes or directly on the wall.

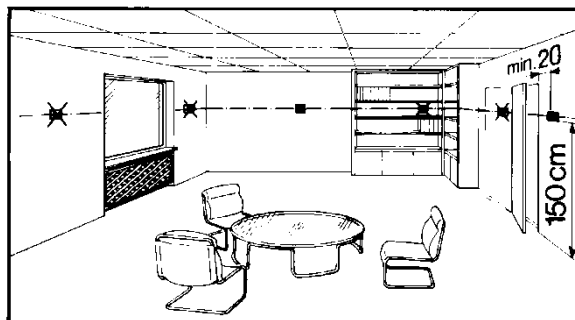

2.2 Installation

Mounting conditions

- Wall
- Boiler control panel
- The controller may not be exposed to dripping water
- Permissible ambient temperature: 0...50 °C

Wall mounting

Step 1

Open the unit at the bottom and remove the base from the housing front.



Step 2

Connect the bus cable to the screw terminals.



Step 3

Fit the base to the wall with the help of screws.



Step 4

Engage the housing front at the top of the base and close the unit to the bottom.



2.3 Electrical installation

Regulations for installation

The local regulations for electrical installations must be complied with.

Connection diagram

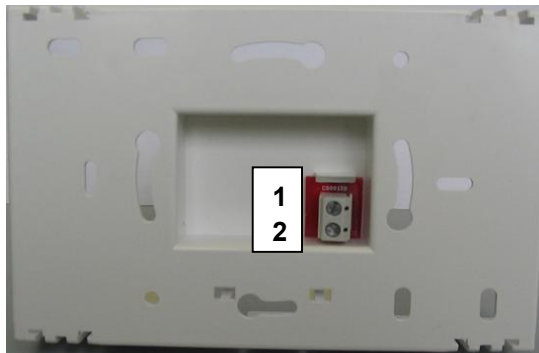

- 1 COA OpenTherm terminal A (interchangeable)
- 2 COB OpenTherm terminal B (interchangeable)

 23 mA max

3 Commissioning

Prerequisites

Prior to commissioning the controller, make the following checks:

- Correct mounting
- Correct connection to OpenTherm bus
- Enduser parameters are set as required
- Heating engineer parameters are set in compliance with plant requirements

At first power up or after a long off period (no power supply), "**CLOW**" is displayed on the LCD for some minutes.

During this first period it is not possible to visualize or change parameters, the other functions are running. After some minutes a minimum back-up time is reached and the full functionality is available

3.1 Operational faults

Room unit

No display on the room unit:

Is the heating plant's main switch turned on?

- Are the fuses in order?
- Check the wiring
- Boiler controller

Boiler control does not switch on

Does boiler control really have to operate?

- Press boiler control's lock-out reset button
- Check wiring and fuse of boiler control
- Check the communication link to boiler control

Room temperature

The room temperature does not agree with the required temperature level:

- Does the room temperature setpoint agree with the required temperature level?
- Is the required operating mode indicated?
- Are weekday, time of day and the displayed heating program correct?
(Info displays)
- Has the heating curve slope been correctly set?
- Check wiring of outside sensor
- Has the "Nominal room temperature setpoint" with the "Parallel displacement of the heating curve" been calibrated based on the effective room temperature?
- Check boiler control

D.h.w.

D.h.w. is not being heated:

- Has the button for d.h.w. heating been pressed?
- Check setpoint of the d.h.w. temperature
- Check d.h.w. function of boiler control







4 Handling

4.1 Operation







Operating elements









Legend

	Operating element	Function
①	Heating circuit operating mode button and associated symbols	 Operating mode changes to: <ul style="list-style-type: none">  Automatic operation  Continuous operation  Protection  Temporary function
②	D.h.w. operating mode button with associated symbol	 D.h.w. heating ON / OFF
③	Setpoint buttons Heating	Adjustment of room temperature setpoint
④	Setpoint buttons D.H.W.	Adjustment of D.H.W. temperature setpoint
⑤	Info button	Change of info display
⑥	Occupancy button	Changeover of operating level
⑦	LCD	Display of data and operating mode

Display icons

	DHW mode ON
	Boiler operation for DHW heat demand
	Maintenance message
	Holiday function
	Heating to Comfort setpoint
	Heating to Reduced setpoint
	Boiler on

	Space heating mode ON
	Boiler operation for heating circuit heat demand
	Automatic operation
	Temporary function
	Continuous operation
	Protection

Display

Display of all symbols and segments.

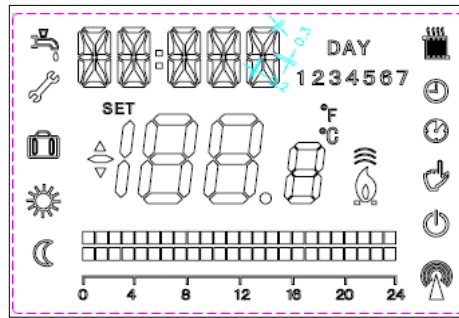

Selection of space heating mode



This setting is used to switch between the different operating modes. The selection made is indicated by a bar which appears below the respective symbol.

Automatic mode

Automatic mode controls the room temperature according to the time program.

Characteristics of automatic mode:

- Heating mode according to the time program
- Temperature setpoints according to the heating program "Comfort setpoint" or "Reduced setpoint"
- Protective functions active
- Automatic summer / winter changeover and automatic 24-hour heating limit (ECO functions) active

Continuous operation

Continuous operation maintains the room temperature at the selected operating level.

Characteristics of continuous operation:

- Heating mode with no time program
- Protective functions active
- Automatic summer / winter changeover and 24-hour heating limit (ECO functions)

inactive in the case of continuous operation with Comfort setpoint

Protection

When using Protection mode, the heating system is off, but it remains protected against frost (frost protection temperature) provided there is no power failure.

Characteristics of Protection:

- Heating off
- Temperature according to frost protection
- Protective functions active
- Automatic 24-hour heating limit (ECO functions) active

Cooling mode (if activated)

Cooling mode controls the room temperature in accordance with the time program.

Characteristics of cooling mode:

- Manual cooling mode
- Cooling mode based on time program
- Temperature setpoint based on "Comfort setpoint" or "Reduced setpoint"

Selecting the DHW heating mode



The button is used to switch DHW heating mode on and off.

DHW heating mode

- On
The DHW is heated according to the selected switching program. A setpoint is generated based on the demand for heat and the settings and passed on to the BMU.
- Off
No DHW heating

DHW shower

This function allows to set a temporary setpoint.
Triggering is effected by keeping the DHW operating mode button for at least 3 seconds.
The setpoint remains active during 55 minutes -> tap symbol is blinking.

Notes

- To deactivate the function before the end of the 55 min press DHW button
- The d.h.w. operating mode and the different d.h.w. functions are active only if supported by boiler control and if communicated in OpenTherm Plus mode



Caution

The QAA73.110 has no frost protection function for d.h.w. heating. Frost protection for d.h.w. must be ensured by boiler control.

Adjusting the room temperature setpoint "tAMB"

- / +



Push the + /- buttons to increase or decrease the **Comfort setpoint**.
The **Reduced setpoint** can be adjusted in programming level.

Adjusting the DHW temperature setpoint "HW SP"

- / +



Push the + /- buttons to increase or decrease the **Nominal setpoint**.
The **Reduced setpoint** can be adjusted in programming level.

Presence button



If you do not use the rooms for a certain period of time, you can press the presence button to reduce the room temperature, thus saving heating energy.

When the rooms are occupied again, press again the presence button to resume heating operation.

- The presence button is only active in automatic operation
- The current selection is active until the next switching action according to the heating program takes place

During the holiday period, the heating circuit operating level changes to frost protection.

The setting range is between 10 minutes and 45 days.

- This function is only active in automatic mode.
- The function can be cancelled by pressing any button



Displaying information



Various data can be displayed by pressing the info button. Depending on the type of unit, configuration and operating state, some of the info lines listed below may not appear.

Display:

Description	Name	Unit
- Boiler temperature	BOILR	°C
- Water pressure	P BAR	Bar
- Outside temperature	EXT T	°C
- Domestic hot water temperature	DHW	°C
- Domestic hot water temperature 2	DHW 2	°C
- Domestic hot water flow rate	DHWFR	l/min
- Relative boiler power	PWR	%
- Fan speed	S FAN	Rpm
- Exhaust temperature	T EXH	°C
- Return temperature	RETUR	°C
- Calculated flow temperature setpoint	CH SP	°C

During boiler operation it is possible to see the actual boiler modulation level on 4 different levels.

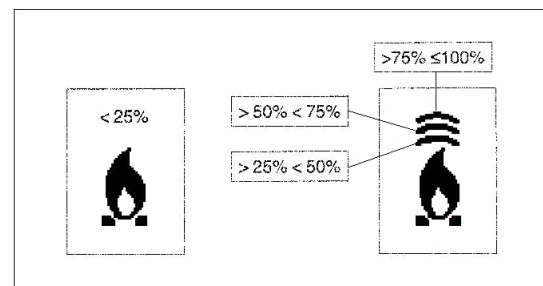

Indication of faults

The room unit indicates faults that may have occurred in the unit itself or in the system

If a fault is indicated '**ERROR**' and the error code followed by the letter '**E**' are visualized in the display.

These faults cannot be reset. They will be cleared only when rectified.

Error code	Description
60	Room sensor
88	Communication
95	Clock
127	Legionella setpoint not reached 1)

1) Can be reset by pressing OK button

Other fault displays

Depending on the type of boiler control, the room unit also displays other error codes. For detailed information, please refer to the technical documentation of the boiler controller used.

Boiler lockout

During boiler lockout, 'ERROR'.and '>>>OK' are blinking alternatively and the error code followed by the letter 'E' are visualized in the display.

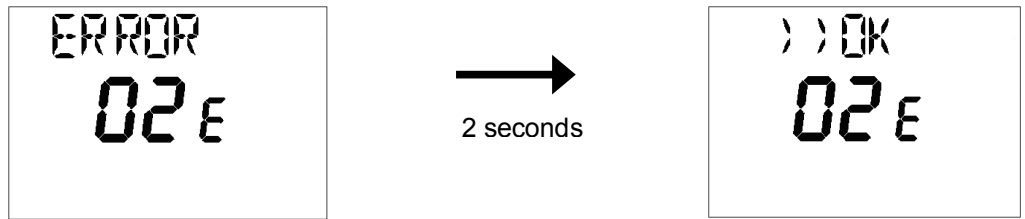

For resetting the BMU press the OK button

If the reset was successful 'RESET' followed by '>>>OK' are visualized in the display.

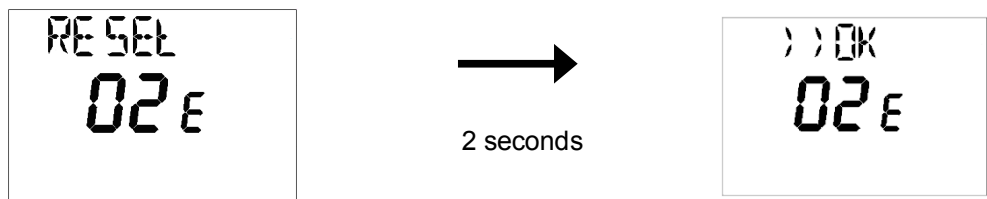

Chimney sweep







Is activated / deactivated on the BMU
Boiler temperature is visualized on the QAA

Controller stop

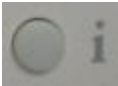
Is activated / deactivated on the BMU
Modulation level can be set by up down buttons

4.2 Programming room units parameters

Setting



	Button	Description
1		Press the Info button for at least 3 seconds. This will take you directly to the programming level "Enduser".
2		The display shows a number of operating pages. Press the line selection buttons to select the required operating page. To confirm, press OK.
3		The display shows a number of operating pages. Press the line selection buttons to select the required operating line. To confirm, press OK.
4		The display shows the value flashing. Press the line selection buttons until value is correct. To confirm, press OK
5		By pressing the ESC button, you come back to operating page selection.
6		By pressing the ESC button, you leave the programming level.

Note

If no button is pressed for about 1 minutes, the room unit will automatically leave programming level.

4.2.1 User levels

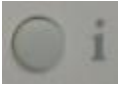
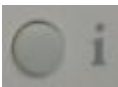
The user levels only allow authorized user groups to make settings. To reach the required user level, proceed as follows:

	Buttons	Explanation
1		Press the Info button for at least 3 seconds. This will take you directly to the programming level "Enduser".
2		Press the Info button for at least 3 seconds. This will take you to the user level selection.
3		You are now given a choice of user levels. Press the line selection buttons to select the required user level. To confirm, press OK. You are now on the required user level.

The following user levels are available

- USR = End user
- INST = Heating engineer
- OEM = OEM

To reach the OEM level, the relevant code must be entered.

4.2.2 Overview of settings

The table shows all available settings up to the heating engineer level. However, certain operating lines may be hidden, depending on the type of unit.

E = End user, F = Heating engineer, O = OEM

Operating line	Operating level	Function	Factory setting	Range	Unit
TIME					
hh:mm	E	Hours/minutes		00:00...23:59	hh:mm
DAY	E	Week day		1...7	
TSPHC					
MO...SU	E	Day selection	MO	1...7	
ON 1	E	1st phase on	06:00	00:00...23:59	hh:mm
OF 1	E	1st phase off	22:00	00:00...23:59	hh:mm
ON 2	E	2st phase on	24:00	00:00...23:59	hh:mm
OF 2	E	2st phase off	24:00	00:00...23:59	hh:mm
ON 3	E	3st phase on	24:00	00:00...23:59	hh:mm
OF 3	E	3st phase off	24:00	00:00...23:59	hh:mm
ON 4	E	4st phase on	24:00	00:00...23:59	hh:mm
OF 4	E	4st phase off	24:00	00:00...23:59	hh:mm
TSPCC 1)					
MO...SU	E	Day selection	MO	1...7	
ON 1	E	1st phase on	10:00	00:00...23:59	hh:mm
OF 1	E	1st phase off	18:00	00:00...23:59	hh:mm
ON 2	E	2st phase on	24:00	00:00...23:59	hh:mm
OF 2	E	2st phase off	24:00	00:00...23:59	hh:mm
ON 3	E	3st phase on	24:00	00:00...23:59	hh:mm
OF 3	E	3st phase off	24:00	00:00...23:59	hh:mm
ON 4	E	4st phase on	24:00	00:00...23:59	hh:mm
OF 4	E	4st phase off	24:00	00:00...23:59	hh:mm
TSPHW					
ON 1	E	1st phase on	06:00	00:00...23:59	hh:mm
OF 1	E	1st phase off	22:00	00:00...23:59	hh:mm
ON 2	E	2st phase on	24:00	00:00...23:59	hh:mm
OF 2	E	2st phase off	24:00	00:00...23:59	hh:mm
ON 3	E	3st phase on	24:00	00:00...23:59	hh:mm
OF 3	E	3st phase off	24:00	00:00...23:59	hh:mm
ON 4	E	4st phase on	24:00	00:00...23:59	hh:mm
OF 4	E	4st phase off	24:00	00:00...23:59	hh:mm
HEAT					
COMFR	E	Comfort setpoint	20	5...35	°C
ECONM	E	Reduced setpoint	18	5...35	°C
NOFRS	E	Frost protection setpoint	5	5...35	°C
HC SL	O	Flow temp setpoint manual	80	20...80	°C
HC MX	F	Flow temp setpoint max OEM	80	20...80	°C
HC MN	F	Flow temp setpoint min	20	20...80	°C
SLOPE	F	Heating curve slope	1,5	0,1...4	
SUWI	F	Summer/winter heating limit	18	8...30	°C







Operating line	Operating level	Function	Factory setting	Range	Unit
ECO24	F	24-hour heating limit	0	-10...+10	°C
KORR	F	Room influence	4	0...20	
BUILD	F	Time constant building	3	0...10	
AMBON	F	Room influence ON/OFF 0 = OFF, 1 = ON	1	0-1	
QSETB	F	Quick setback ON/OFF 0 = OFF, 1 = ON	1	0-1	
SDR	F	Room temp limitation	0,5	0,5...4,0	°C
HC2SR 2)	F	Room temperature setpoint for heating circuit 2	20	5...35	°C
HC2SF 2)	F	Flow temperature setpoint heating circuit 2	80	20...80	°C
COOL 1)					
COMFR	E	Comfort setpoint	22	5...30	°C
ECONM	E	Reduced setpoint	24	5...30	°C
DHW					
COMFR	F	Nominal setpoint	55	35...70	°C
ECONM	F	Reduced setpoint	35	35...70	°C
SHOWR	O	Shower function setpoint	40	35...70	°C
HW MX	F	DHW setpoint max	65	35...70	°C
HW MN	F	DHW setpoint min	35	35...70	°C
L FCT	F	Legionella function 0 = OFF, 1 = ON	0	0...2	
L TIME	F	Legionella function dwelling time	1	1...180	Min
L TEMP	F	Setpoint of legionella function	65	35...70	°C
CONF					
HW PR	F	DHW program	1	0...2	
COOL	F	COOLING ON/OFF 0 = OFF, 1 = ON	0	0-1	
RESET	O	Reset to default parameters 0 = NO, 1 = YES	0	0-1	

- 1) This menu is only visible if parameter COOL is ON
2) Only active when supported by BMU

4.3 Programming Siemens BMU parameters

This functionality is available only on some BMU's.

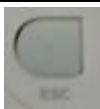
Setting



	Buttons	Explanation
1		Press the line selection buttons for at least 3 seconds. This will take you directly to the programming level "Enduser".
2		The display shows a number of operating pages. Press the line selection buttons to select the required operating page. To confirm, press OK.
3		The display shows a number of operating pages. Press the line selection buttons to select the required operating line. To confirm, press OK.
4		The display shows the value flashing. Press the line selection buttons until value is correct. To confirm, press OK.
5		By pressing the ESC button, you come back to operating page selection.
6		By pressing the ESC button, you leave the programming level.

Note

If no button is pressed for about 1 minutes, the room unit will automatically leave programming level.

User levels

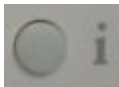
The user levels only allow authorized user groups to make settings. To reach the required user level, proceed as follows:

	Buttons	Explanation
1		Press the line selection buttons for at least 3 seconds. This will take you directly to the programming level "Enduser".
2		Press the Info button for at least 3 seconds. This will take you to the user level selection.
3		You are now given a choice of user levels. Press the line selection buttons to select the required user level. To confirm, press OK. You are now on the required user level.

The following user levels are available

- USR = End user
- INST = Heating engineer
- OEM = OEM

To reach the OEM level, the relevant code must be entered.

Note

For detailed information, please refer to the technical documentation of the boiler controller used.

5 Description of room unit settings

5.1 Time and day (TIME)

Lines
(hh:mm, DAY)

To ensure proper functioning of the heating program, the time switch with the time of day and the weekday must be correctly set.

Time of day and weekday are important, ensuring that the heating program, the cooling program and the d.h.w. program operate as required.

5.2 Time switch program (TSPHC, TSPCC)

5.2.1 Day selection

Lines
(MO...SU)

With this setting, you select the weekdays or the day block for which the switching times of the time switch program apply.

- This setting must be made before the switching times are entered!
- For every day on which other switching times shall apply, the preselection of the individual day with subsequent entry of the switching times must be repeated

Entry of 7-day block

Entry of the switching times on lines 'ON 1' through 'OFF 4' is identical for every day from Monday through Sunday

Example of a time switch program valid for all weekdays

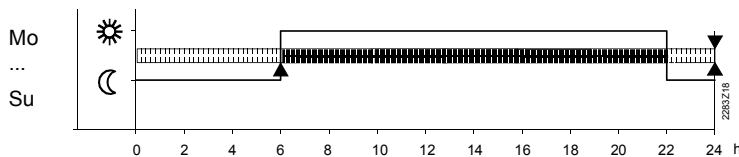

Entry of individual days

Entry of the switching times on lines 'ON 1' through 'OF 4', are only entered for the individual day selected here

Example of a 7-day time switch program:

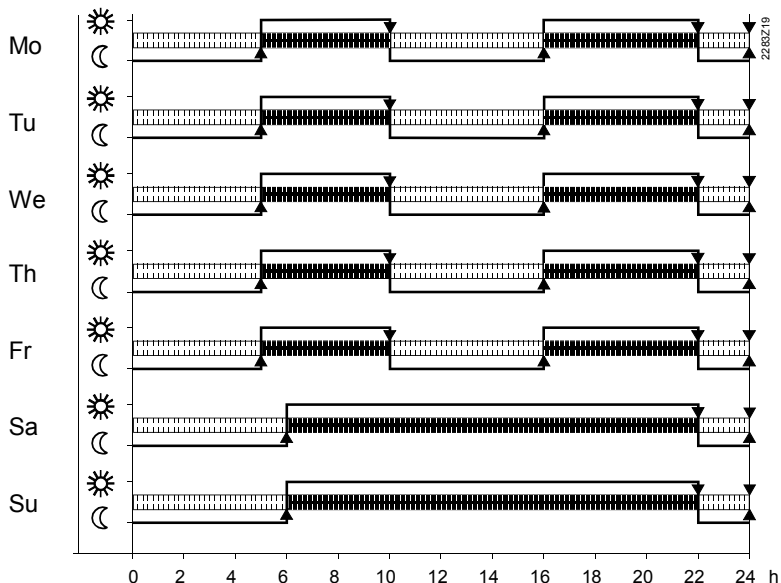

Tip First, choose the 7-day block to enter the switching times required for the majority of days; then, select the individual days to make the required adjustments.

5.2.2 Switching times

Lines (ON 1 ...OF 4)

This setting defines the switching times for space heating and d.h.w. heating. The temperature setpoints of the 2 heating circuits and the d.h.w. usage times change at the times set.

Important

First, select the weekday for which the switching times shall be entered!

5.3 Heating circuit (HEAT)

Comfort room temperature setpoint (COMFR)

In comfort operation, the comfort room temperature setpoint is maintained.

The comfort room temperature setpoint is adjusted with the buttons for the comfort temperature, which are located on the controller front for direct access by the user. When a button is pressed, the current room temperature setpoint is displayed and – when pressed further – readjusted.

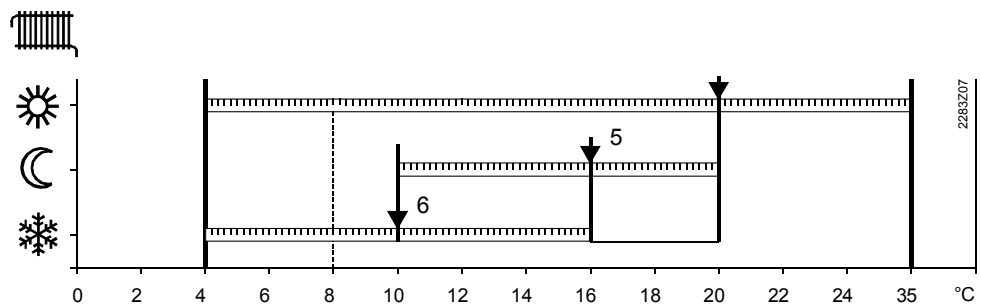

Room temperature setpoint setting ranges

- 5 Reduced room temperature setpoint (ECONM)
- 6 Frost protection setpoint of the room temperature (NOFRS)

When the comfort room temperature setpoint is active, the rooms will be heated according to the adjustment made with the setpoint buttons. The adjustment made with the buttons is only active in automatic and continuous operation.

Example

The comfort phases depend on the settings made on lines 'ON 1' through 'OF 4'.

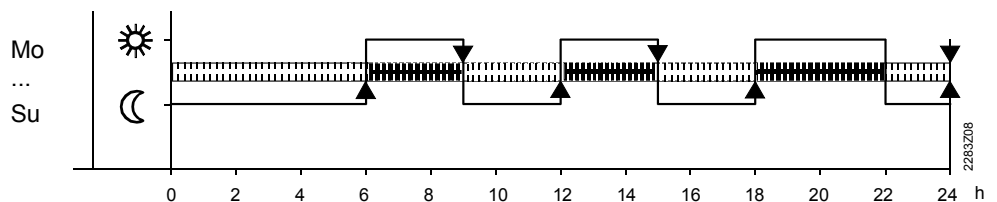

Comfort temperature and reduced temperature phases for heating circuit.

Reduced room temperature setpoint (ECONM)

The reduced room temperature setpoint ensures a lower room temperature during the night, for instance, to save energy.

It is not possible to set the reduced setpoint above the adjustment made on comfort room temperature setpoint.

During the reduced phases, the reduced room temperature setpoint C is maintained. Any lower comfort temperature is given priority however.

Frost protection room temperature setpoint (NOFRS)

This function prevents the room temperature from falling below the adjusted frost protection setpoint.

This setting will change the frost protection setpoint of the room temperature.



Caution

- This function is ensured only when the heating plant operates properly!
- Frost protection for the boiler and the d.h.w. must be ensured by the boiler control.

Minimum and maximum limitation of flow temperature (CH MX, CH MN)

Minimum and maximum limitation define the range within which the flow temperature setpoint may vary. They prevent too low or too high flow temperatures.

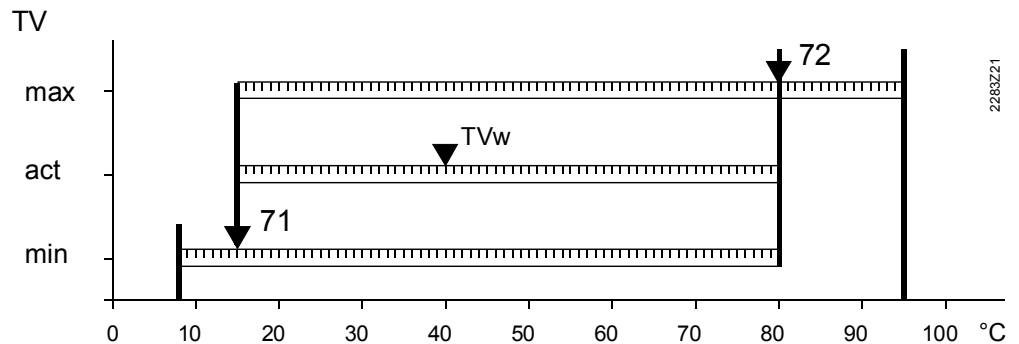

TVw Current flow temperature setpoint

71 minimum limitation of flow temperature (CH MN)

72 maximum limitation of flow temperature (CH MX)

These settings provide maximum or minimum limitation of the flow temperature.

Important

Maximum limitation is NOT to be regarded as a safety function as required with underfloor heating systems, for example.

Heating curve slope (SLOPE)

The room unit generates the flow temperature setpoint based on the selected heating curve. The result is a constant room temperature irrespective of outside temperature variations.

By changing the setting, the slope of the heating curve will be increased or decreased with the following effects:

Increase: The flow temperature will be **raised** when the outside temperature drops

Decrease: The flow temperature will be **raised less** when the outside temperature drops

The following settings produce the following effects:

2.5...40.0 The room unit delivers a weather-compensated flow temperature for the respective heating circuit.

-- . - The relevant heating circuit is deactivated.

Note

The programmed heating curve is based on a room setpoint of 20°C. If the room setpoint is adjusted, the heating curve automatically adapts to the new value.

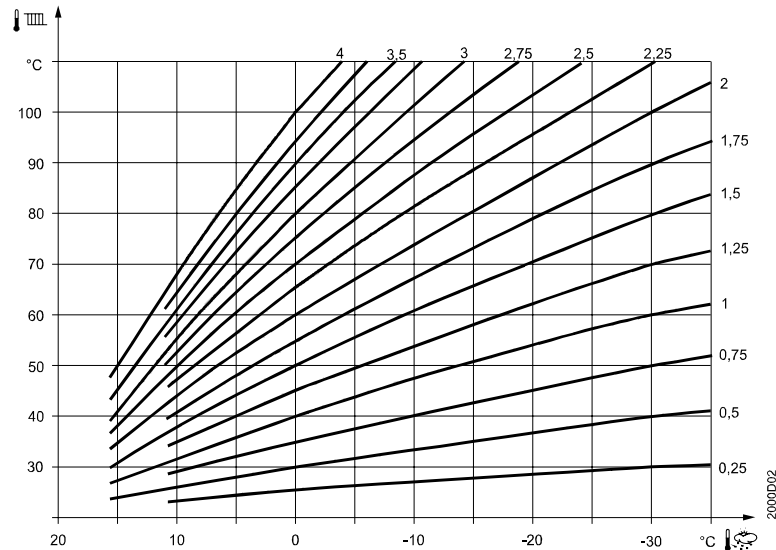

**Summer / winter
changeover
temperature (SUWI)**

The summer / winter changeover temperature is the criterion for automatic summer / winter changeover of the heating plant.

It offers the following benefits:

- Fully automatic operation throughout the year
- The heating will not be switched on when the outside temperature drops for short periods of time
- Additional savings function

By changing the setting, the respective periods of time will be shortened or extended. The change will only affect the heating circuit.

Increase: Winter operation will start *earlier*
Summer operation will start *later* .

Decrease: Winter operation will start *later*
Summer operation will start *earlier*

To determine changeover, the setting of the summer / winter changeover temperature (± a fixed switching differential) is compared with the attenuated outside temperature.

Heating OFF (from winter to summer)	Taged > SuWi +1 °C
Heating ON (from summer to winter)	Taged < SuWi -1 °C

Note

This function only acts in automatic mode.

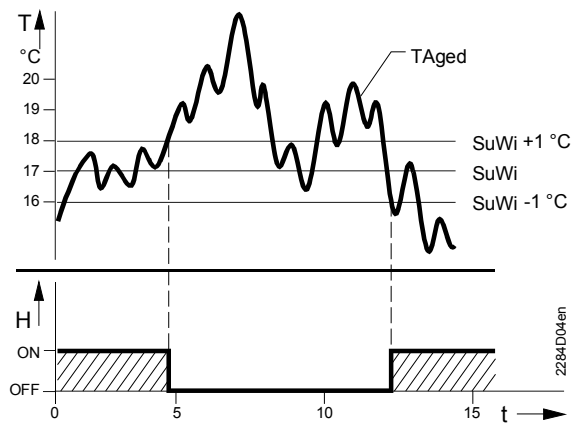

Legend

- T Aged Attenuated outside temperature
- SuWi Summer / winter changeover temperature
- T Temperature
- t Time in days
- H Heating

24-hour heating limit (ECO24)

The 24-hour heating limit is used to switch the heating on and off in the course of the day, depending on the outside temperature. This function is used primarily during spring and autumn to respond to short-term temperature variations.

Example:

Setting line	e.g.
Comfort setpoint (TRw)	22 °C
24-hour heating limit (THG)	-3 °C
Changeover temperature (TRw-THG) heating off	= 19 °C
Switching differential (fixed)	-1 °C
Changeover temperature heating on	= 18 °C

By changing the value entered, the respective heating periods will be shortened or extended.

Increase: Heating mode will start *earlier*,
changeover to ECO *later*.

Decrease: Heating mode will start *later*,
changeover to ECO *earlier*.



- The function is not active in operating mode "Continuously Comfort temperature" ☀
- To give consideration to the building's thermal dynamics, the outside temperature will be attenuated

Gain factor of room influence (KORR)

Defines the influence of room temperature setpoint deviations on the controlled system. The room influence can be activated and deactivated (operating line 75).

Changing this setting has the following impact:

Increase: Authority of room influence will increase

Decrease: Authority of room influence will decrease

The following example shows how and according to which formula the room temperature setpoint will be corrected.

Room temperature setpoint TRw = Actual room temperature
 TRx = 22 °C
 Correction factor KORR = 8

$$TRwk = TRw + \frac{KORR}{2} (TRw - TRx)$$

$$TRwk = 20 \text{ °C} + 4 (20 \text{ °C} - 22 \text{ °C}) = 12 \text{ °C}$$

KORR Constant for room influence
 TRx Actual value of the room temperature
 TRw Room temperature setpoint
 TRwk Room temperature setpoint (readjusted)

As the example shows, if the room temperature is 2 °C too high, the room influence temporarily shifts the room temperature setpoint down to a level of 12 °C.

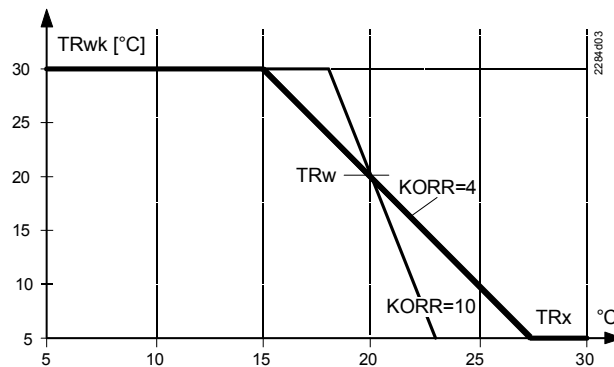

Note

KORR works only if the room temperature influence is activated.

Type of building construction (BUILD)

Enables the control system's rate of response to be matched to the type of building construction.

When the outside temperature varies, the room temperature changes at different rates, depending on the building's thermal storage capacity.

The above setting ensures that the generation of the composite outside temperature will be matched to the type of building construction. Also refer to "Composite outside temperature".

5...10 Heavy building structures:

The room temperature will respond **slower** to outside temperature variations

1...5 Light building structures:

The room temperature will respond **quicker** to outside temperature variations

Room influence (AMBON)

Owing to the temperature checkback signal received from the room, a constant room temperature is maintained and, if required, quick setback enabled.

Room temperature deviation is the temperature differential between actual room temperature and room temperature setpoint.

The setting will activate the room influence on the heating circuit.

Room influence

Deviations of the actual room temperature from the setpoint are acquired and taken into account by temperature control.

To be able to use the control variant "Weather compensation with room influence", the following conditions must be satisfied:

- An **outside sensor** must be connected to boiler control
- Room influence **must** be enabled to act on the relevant heating circuits
- There may be **no thermostatic radiator valves** in the reference room (If such valves are present, they must be set to their fully open position).

Quick setback (QSETB) During quick setback, the heating circuit pump is deactivated.

- **Function with room sensor:**
When using the room sensor, the function keeps the heating switched off until the room temperature has dropped to the level of the reduced setpoint or the frost level.
When the room temperature has fallen to the reduced level or the frost level, the heating circuit pump will be activated and the mixing valve will be released.
- **Function without room sensor:**
Quick setback switches the heating off for a certain period of time, depending on the outside temperature and the building time constant.

Example

Duration of quick setback when Comfort setpoint minus Reduced setpoint = 2 °C (e.g. Comfort setpoint = 20 °C and Reduced setpoint = 18 °C)

Outside temperature composite:	Building time constant:						
	0	2	5	10	15	20	50
15 °C	0	3.1	7.7	15.3	23	30.6	76.6
10 °C	0	1.3	3.3	6.7	10	13.4	33.5
5 °C	0	0.9	2.1	4.3	6.4	8.6	21.5
0 °C	0	0.6	1.6	3.2	4.7	6.3	15.8
-5 °C	0	0.5	1.3	2.5	3.8	5.0	12.5
-10 °C	0	0.4	1.0	2.1	3.1	4.1	10.3
-15 °C	0	0.4	0.9	1.8	2.6	3.5	8.8
-20 °C	0	0.3	0.8	1.5	2.3	3.1	7.7
Duration of quick setback in hours							



- T Quick setback is possible with or without a room sensor

Room temperature maximum limitation (SDR)

It is used for room temperature limitation. This function prevent rooms from getting overheated.

The switching differential for 2-position control will be changed.

- . – Switching differential is inactive
 - The pump always remains activated
- Decrease: Switching differential will become smaller
 - The pumps are switched on and off more often
 - The room temperature varies within a narrower band
- Increase: Switching differential will become greater
 - The pumps are switched on and off less often
 - The room temperature varies within a wider band

With pump heating circuits, the amount of heat supplied is controlled by switching the pumps on and off. This is accomplished with 2-position control by means of the room temperature's switching differential.

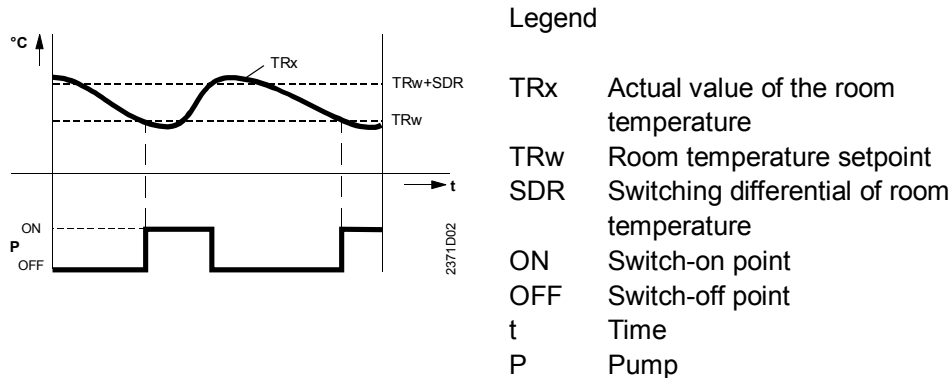

Pump ON	$TRx = TRw$
Pump OFF	$TRx = TRw + SDR$

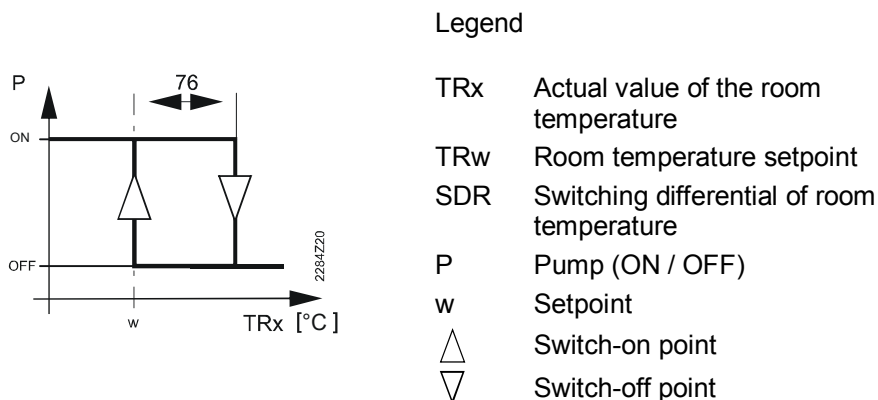

Note The heating circuit pumps are controlled not directly by the QAA73.110, but by boiler control. For this reason, this functionality is not ensured by the room unit alone.

(HC2SR) Room temperature setpoint for heating circuit 2. Active only if supported by BMU.

(HC2SF) Flow temperature setpoint for heating circuit 2. Active only if supported by BMU.

5.4 Cooling circuit (COOL)

Comfort room temperature setpoint (COMFR)

In comfort operation, the comfort room temperature setpoint is maintained.

The comfort room temperature setpoint is adjusted with the buttons for the comfort temperature, which are located on the controller front for direct access by the user. When a button is pressed, the current room temperature setpoint is displayed and – when pressed further – readjusted.

Reduced room temperature setpoint (ECONM)

The reduced room temperature setpoint ensures a higher room temperature during the night, for instance, to save energy.

5.5 Domestic hot water (DHW)

Nominal DHW temperature setpoint (COMFR)

During nominal operation, the nominal d.h.w. setpoint is maintained. It is possible to use 2 different d.h.w. temperature setpoints.

The temperature setpoint during normal d.h.w. operation will be changed.

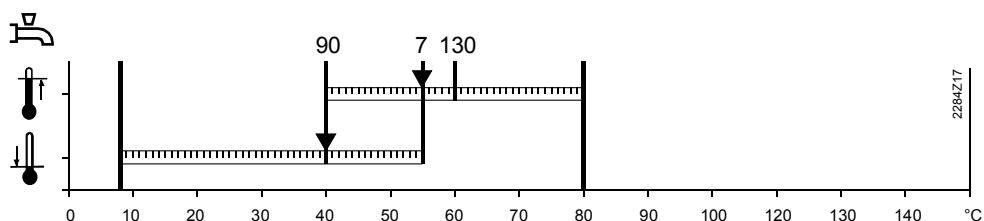

- 7 Nominal d.h.w. temperature setpoint (COMFR)
- 90 Reduced setpoint of the d.h.w. temperature (ECONM)
- 130 Maximum nominal setpoint of d.h.w. temperature (HW MX)

Reduced DHW temperature setpoint (ECONM)

Reduction of the d.h.w. temperatures outside main occupancy times.

The time switch integrated in the room unit automatically switches between main and secondary occupancy times.

D.h.w. is at a high temperature level only if required. This saves energy by reducing the temperature when not in use.

The temperature setpoint during reduced d.h.w. operation will be changed.

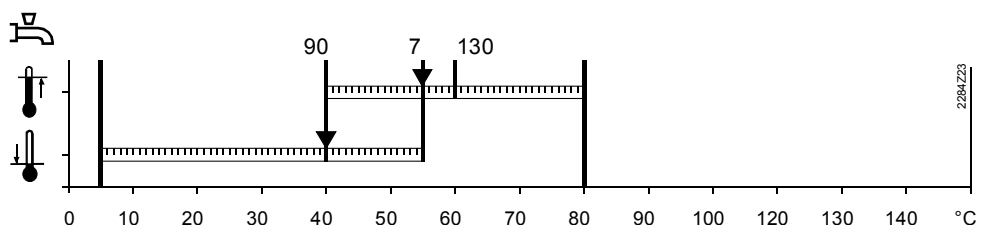

- 7 Nominal d.h.w. temperature setpoint (COMFR)
- 90 Reduced setpoint of the d.h.w. temperature (ECONM)
- 130 Maximum nominal setpoint of d.h.w. temperature (HW MX)

Maximum DHW temperature setpoint (HW MX)

- Function for limiting the maximum settable nominal setpoint of the d.h.w. temperature.

Note

A d.h.w. setpoint maximum (TBWmax) of a BMU transmitted via OpenTherm is given priority and replaces that of the room unit (setting 130).

Minimum DHW temperature setpoint (HW MN)

- Function for limiting the minimum settable nominal setpoint of the d.h.w. temperature.

Note

A d.h.w. setpoint minimum (TBWmin) of a BMU transmitted via OpenTherm is given priority and replaces that of the room unit (setting 130).

Legionella function (L FCT)

The legionella function ensures that the d.h.w. in the storage tank will periodically be raised to a temperature higher than nominal setpoint.

The setting activates or deactivates the legionella function. Entry:

OFF Function inactive

Weekly ON: Function is activated every Monday morning when d.h.w. is heated up for the first time and lasts a maximum of 2.5 hours. The d.h.w. is heated up to the adjusted legionella setpoint.

Daily Function is activated every day when d.h.w. is heated up for the first time and lasts a maximum of 2.5 hours. The d.h.w. is heated up to the adjusted legionella setpoint.

Notes

- If on the starting day of the legionella function, d.h.w. is not heated, or if the function is aborted, it will be repeated the next day when d.h.w. is heated for the first time.
- This function is possible only when d.h.w. heating is released by the d.h.w. heating program.

Dwelling time at legionella function setpoint (L TIME)

The setpoint of the legionella function (operating line 92) is maintained for at least the period of time set here.

--- Function deactivated (no dwelling time)

The dwelling time starts as soon as the legionella setpoint is reached. During the entire dwelling time, the temperature may not fall below the legionella setpoint by more than the set BMU d.h.w. switching differential. The legionella function is terminated when this criterion is met.

Setpoint of the legionella function (L TEMP)

The setpoint of the legionella function is an adjustable temperature level to which the d.h.w. temperature is raised when the legionella function is activated. The setting changes the d.h.w. setpoint during the period of time the d.h.w. is heated up as a result of the legionella function.

5.6 Configuration (CONF)

TSP DHW enable (HW PR)	The setting activates or deactivates time switch program. 0: DHW OFF 1: DHW always ON 2: DHW time switch program active
Cooling enable (COOL)	The setting activates or deactivates the cooling function
Default paramters (RESET)	All parameters can be reset to their default values.

6 Functions

Introduction

The functions described below require no settings. They are performed automatically but have an impact on the plant.

For the rectification of faults, planning and plant maintenance, it may therefore be very advantageous to know about their impact on plant operation.

6.1 Types of compensation

The room unit offers 3 types of compensation each of which generates the effective flow temperature setpoint in a different way. They are the following:

- Weather compensation
- Weather compensation with room influence
- Room compensation
- Fix flow temperature setpoint

6.1.1 Weather compensation

Description

With this type of compensation, the building's heat losses are compensated by an adequate flow temperature.

The colder the weather, the quicker the building cools down and the greater the heating circuit's heat demand.

With this type of compensation, it must be ensured that the heating curve is correctly set, because the room unit gets **no feedback from the space** whether the amount of heat supplied meets the demand of the users.

Prerequisites

The room influence (AMBON) must be set to "OFF" and, in addition, an outside sensor must be connected.

6.1.2 Weather compensation with room influence

Description

Compared to pure weather compensation, this type of compensation offers enhanced comfort because with the room influence, the room unit gets a feedback from the space.

Prerequisites

The room influence (AMBON) must be activated for the required heating circuits and, in addition, an outside sensor must be connected.

Room influence

The room influence acts on the room temperature setpoint. The deviation of setpoint / actual value of the room temperature is multiplied by the correction factor KORR/2 and added to the deviation from the room temperature setpoint in the opposite direction.

Room influence acts:

- In the case of deviations of setpoint / actual value of the room temperature
- With automatic or manual changeover to a higher or lower room temperature setpoint

6.1.3 Room compensation

Description	With pure room compensation, a PID control algorithm is activated. This is the preferred control mode if the room temperature is the only compensating variable available. The selected control algorithm gives consideration to both the actual value of the room temperature and the current slope (gradient). The P-part is generated by the control deviation, the D-part from the gradient of the room temperature. The I-part suppresses continuous deviations of setpoint / actual value.
Prerequisites	The room influence (AMBON) must be activated for the required heating circuits and, in addition, no outside sensor may be connected.
Effect	The flow temperature and thus the room temperature are controlled as a function of the actual room temperature and its current development. For example, if the room temperature rises slightly, the flow temperature will immediately be reduced even if there is deviation of setpoint / actual value apparent yet. To prevent continuous deviations, the I-part of PID control keeps the room temperature at the required level.

6.1.4 Fix flow temperature setpoint

Description	The setpoint has to be set manually.
Prerequisites	The room influence (AMBON) must be set to "OFF" and, in addition, no outside sensor may be connected.

7 Dimensions

Dimensions in mm

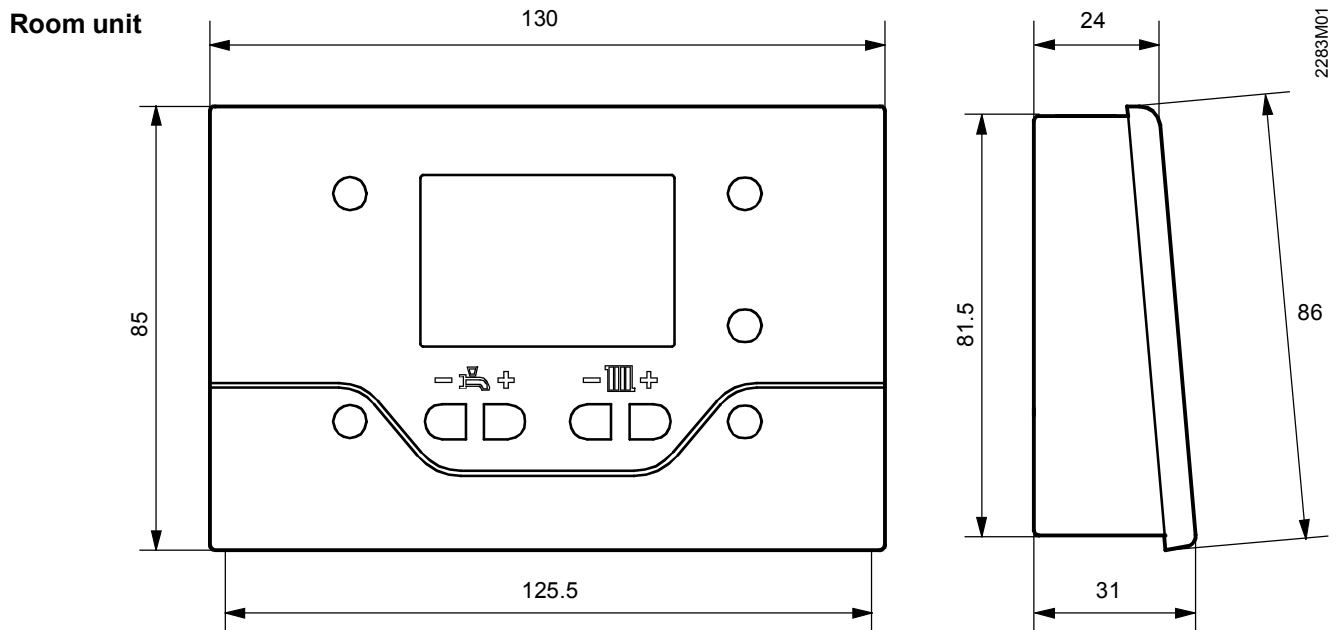

Panel cutout

For special applications it is possible to integrate the device in the boiler panel.

The controller's mounting dimensions are 81.5 x 125.5 mm.

The mechanical mounting facility allows the controller to be fitted in front panels having a thickness of 1 to 2 mm.

8 Technical data

Power supply, interface	OpenTherm Bus		
	Terminals	2-wire, interchangeable	
	Cable length	max. 50 m	
	Cable resistance	max. 2 x 5 Ω	
	Power consumption	20 mW (typically)	
Room temperature measurement	Measuring range	0...50 °C	
	According to EN12098:		
	Range 15...25 °C	within tolerance of 1.3 K	
	Range 0..15 °C or 25...50 °C	within tolerance of 1.6 K	
	Resolution	1/10 K	
Housing protection	as per EN 60529	IP20	
	Protection class	III for proper installation	
	Degree of contamination	Normal contamination	
	Environmental conditions	as per EN 60721-3-1 Storage	class 1K3, -20...70 °C
		as per EN 60721-3-2 Transportation	class 2K3, -25...70 °C
		as per EN 60721-3-3 Operation	class 3K5, 0...50 °C (without condensation)
Standards and directives	Product standard Automatic electronic controls for household and similar use	EN 60730-1	
	Electromagnetic compatibility		
	Immunity (industrial & domestic)	EN 60730-1	
	Emissions (domestic)	EN 60730-1	
	CE conformity		
	Meets requirements of EMC directive	2004/108/EC	
	 Reduction of hazardous substances	2002/95/EC	
Other features	Backup of time	min. 12 h	
	Software class	A to EN 60 730	
	Weight with / without packaging	0.152 kg / 0.115 kg	
	Dimensions	See diagram	

Index

D		
dimensions of cutout.....	32	
dwelling time legionella function.....	28	
E		
engineering.....	6	
H		
handling.....	6	
L		
legionella function.....	28	
dwelling time	28	
M		
maximum d.h.w. setpoint (TBWmax).....	28	
maximum limitation of setpoint rise.....	30	
P		
product liability	6	
protection against legionella viruses	28	
S		
setpoint of legionella function.....	28	
summer operation	22	
T		
technical data.....	33	
W		
weather compensation	30	
weather compensation with room influence.....	30	
winter operation.....	22	

Siemens Switzerland Ltd
Building Technologies Division
International Headquarters
Gubelstrasse 22
6301 Zug
Switzerland
Tel. +41 41-724 24 24
www.siemens.com/buildingtechnologies

© Siemens Switzerland Ltd, 2010
Subject to change