

SIEMENS



Heating Controllers RVP201 and RVP211 Basic Documentation

Edition 1.0
Controller series A
CE1P2464en
12.12.2007

Building Technologies

Siemens Switzerland Ltd
Building Technologies Group
International Headquarters
Gubelstrasse 22
CH-6301 Zug
Tel. +41 41-724 24 24
Fax +41 41-724 35 22
www.siemens.com/sbt

© 2007 Siemens Switzerland Ltd
Subject to change

Contents

1	Summary	7
1.1	Brief description and features	7
1.2	Type summary	7
1.3	Equipment combinations	7
1.3.1	Suitable sensors	7
1.3.2	Suitable room units	8
1.3.3	Suitable actuators	8
1.3.4	Product documentation	8
2	Use	9
2.1	Field of use with regard to plants	9
2.2	Field of use with regard to types of buildings	9
2.3	Field of use with regard to heating systems	9
2.4	Field of use with regard to functions	9
2.5	Application examples	10
2.5.1	Flow temperature control with RVP201	10
2.5.2	Boiler temperature control with RVP201	10
2.5.3	Boiler temperature control with RVP211, d.h.w. heating with charging pump	10
2.5.4	Boiler temperature control with RVP211, d.h.w. heating with changeover valve	10
2.5.5	Flow temperature control with RVP211	11
3	Technical design	12
3.1	Operating modes	12
3.2	Acquisition of actual values	13
3.2.1	General remarks about faults in the measuring circuits	13
3.2.2	Flow or boiler temperature	13
3.2.3	Outside temperature	13
3.2.4	Room temperature	13
3.2.5	D.h.w. temperature	14
3.3	Flow or boiler temperature control	14
3.3.1	Setpoint adjustments	14
3.3.2	Heating program	14
3.3.3	Compensating variables	14
3.3.4	Heating curve chart	16
3.3.5	Generation of setpoint	17
3.3.6	Control	19
3.3.7	Control process	20
3.3.8	Limitations	21
3.4	Optimization functions	21

3.4.1	Boost heating	21
3.4.2	Quick setback	22
3.5	ECO automatic energy saver	22
3.5.1	Fundamentals	22
3.5.2	Compensating and auxiliary variables	23
3.5.3	Heating limit	23
3.5.4	Mode of operation of ECO function 1	23
3.5.5	Mode of operation of ECO function 2	23
3.6	Frost protection for the plant and the building	24
3.6.1	Frost protection for the plant	24
3.6.2	Frost protection for the building	24
3.7	D.h.w. heating	25
3.7.1	General	25
3.7.2	Acquisition of d.h.w. temperature	25
3.7.3	D.h.w. heating with charging pump	25
3.7.4	D.h.w. heating with changeover valve	26
3.7.5	Frost protection	26
3.8	Pump control	27
3.8.1	Pump overrun	27
3.8.2	Pump kick	27
3.9	Interactions with room units	28
3.9.1	General	28
3.9.2	Interactions with room unit QAW50	28
3.9.3	Interactions with room unit QAW70	29
4	Handling	31
4.1	Operation	31
4.1.1	Operating elements	31
4.1.2	Setting and readjusting the room temperature	32
4.1.3	Selection of operating mode	33
4.2	Mounting	33
4.2.1	Mounting location	33
4.2.2	Mounting methods	33
4.2.3	Installation	33
5	Engineering	35
5.1	Connection terminals	35
5.1.1	Low voltage side	35
5.1.2	Mains voltage side	35
5.1.3	Auxiliary terminals	35
5.2	Connection diagrams	36
5.2.1	Low voltage side	36
5.2.2	Mains voltage side	37

6	Mechanical design.....	38
6.1	Controller.....	38
6.1.1	Basic design.....	38
6.1.2	Dimensions.....	38
6.1.3	Outside view.....	39
6.2	Time switches.....	39
6.2.1	General.....	39
6.2.2	Analog time switches AUZ3.....	39
6.2.3	Digital weekly time switch AUD3.....	40
7	Technical data.....	41

1 Summary

1.1 Brief description and features

- RVP201 and RVP211 are heating controllers designed for use in smaller plants. The only difference between the two types of controllers is the d.h.w. heating function:
 - RVP201: without d.h.w. heating
 - RVP211: with d.h.w. heating
- The RVP201/211 controller is designed for use in smaller residential and non-residential buildings that have their own heat generating plant
- The RVP201/211 is a flow temperature controller. In terms of control, the following choices exist:
 - Weather-compensated only
 - Weather- and room temperature-compensated
 - Room temperature-compensated only
- On the output side, the RVP201/211 offers the following choices:
 - Control of three-position actuators
 - Control of two-position actuators
 - Direct burner control
- The controller features analog operating elements such as switches, sliders and setting knobs, with one exception – the optional digital time switch
- Other key features: operating voltage AC 230 V, CE conformity, overall dimensions to IEC 61554 (144 x 96 mm)

1.2 Type summary

<i>Type summary</i>	<i>Type ref.</i>
Heating controller, without time switch	RVP201.0
Heating controller, with analog 24-hour time switch	RVP201.1
Heating controller with d.h.w. heating, without time switch	RVP211.0
Heating controller with d.h.w. heating, with analog 24-hour time switch	RVP211.1
Analog 24-hour time switch	AUZ3.1
Analog weekly time switch	AUZ3.7
Digital weekly time switch	AUD3

1.3 Equipment combinations

1.3.1 Suitable sensors

To acquire the flow or boiler, and the d.h.w. temperature, all sensors with LG-Ni 1000 sensing element can be used; for example:

- Clamp-on temperature sensor QAD22
- Immersion temperature sensor QAE212... or QAP21.3

To acquire the outside temperature, the following types of sensors can be used:

- Outside sensor QAC22 (LG-Ni 1000 sensing element)
- Outside sensor QAC32 (NTC 575 sensing element)

To acquire the room temperature, the following types of sensors can be used:

- Room temperature sensor QAA10
- Room temperature sensor QAW44, only together with room unit QAW70

1.3.2 Suitable room units

For remote operation and for acquiring the room temperature, the following types of room units can be used:

- Room unit QAW50
- Room unit QAW70

1.3.3 Suitable actuators

- For three-position control, electric or electro-hydraulic actuators from Siemens with the following features can be used:
 - Operating voltage AC 24...230 V
 - Maximum running time 6 minutes (ideally 2 to 3 minutes)
- For two-position control, electro-thermal actuators with the following features are suited:
 - Operating voltage AC 24...230 V
 - Running time 8...16 minutes

1.3.4 Product documentation

<i>Type of documentation</i>	<i>Document number</i>	<i>Part number</i>
Data sheet RVP201/211	N2464	
Operating Instructions (languages: de, en, fr, nl, sv, fi, da, it, es, el)	B2464	74 319 0613 0
Installation Instructions (languages: de, en, fr, nl, sv, fi, da, it, es, el)	G2464	74 319 0614 0
CE Declaration of Conformity	T2464	
Environmental Declaration	E2464	
Operating instructions AUD3	B2463	
Data sheet QAW50	N1635	
Data sheet QAW70	N1637	

2 Use

2.1 Field of use with regard to plants

The RVP201/211 is suitable for use in

- heating plants that employ weather- or room temperature-compensated flow temperature control
- heating plants with their own heat generation and own d.h.w. heating facility

2.2 Field of use with regard to types of buildings

The RVP201/211 is basically suited for all types of buildings that use weather- or room temperature-compensated heating control systems. The controllers are however designed specifically for:

- smaller multi-family houses
- one-family houses
- smaller non-residential buildings

2.3 Field of use with regard to heating systems

The RVP201/211 is suitable for use with all known heating systems, such as:

- radiators
- convectors
- underfloor heating systems
- ceiling heating systems
- radiating panels

2.4 Field of use with regard to functions

The RVP201/211 is suitable for use in plants where one or several of the following functions are required:

- Weather-compensated flow or boiler temperature control without room temperature influence
- Weather-compensated flow or boiler temperature control with room temperature influence
- Room temperature-compensated flow temperature control
- Flow temperature control through modulating control of a seat or slipper valve, **or**
- Boiler temperature control through direct control of a single-stage burner
- Control of d.h.w. temperature (only with RVP211)
- Room temperature-compensated boost heating and quick setback
- ECO automatic energy saver: load-dependent switching on and off of heating in function of the outside temperature
- 24-hour time switch for entering the daily occupancy times, **or**
- Weekly time switch for entering the weekly occupancy times
- Remote operation via room unit and with external contact
- Frost protection for the plant, the boiler and the space
- Maximum limitation of flow or boiler temperature
- Indication of faults in the controller and in the measuring circuits by means of LEDs
- Periodic pump run
- Pump overrun

2.5 Application examples

2.5.1 Flow temperature control with RVP201

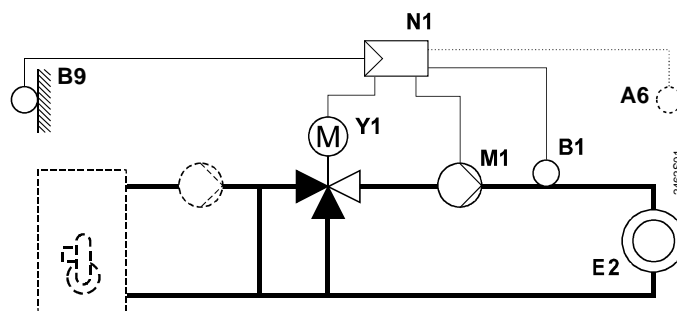

Three-position control, acting on mixing valve

2.5.2 Boiler temperature control with RVP201

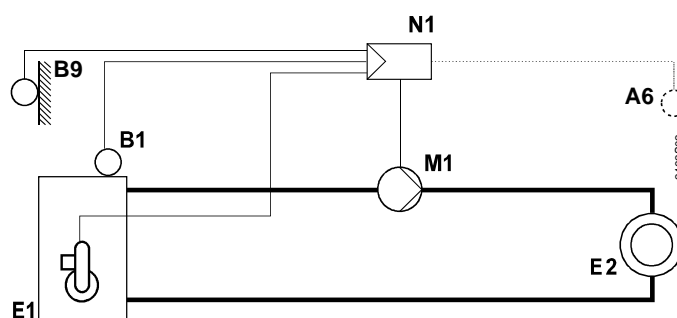

Two-position control, acting on burner

2.5.3 Boiler temperature control with RVP211, d.h.w. heating with charging pump

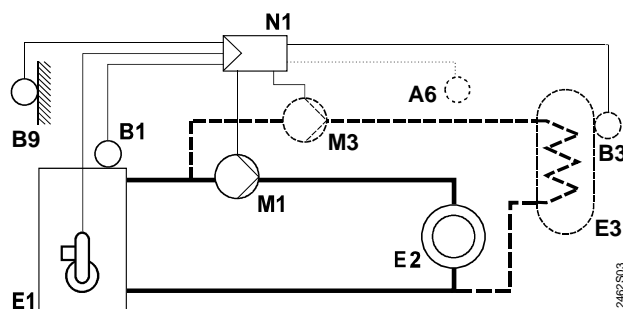

Two-position control, acting on burner, d.h.w. heating with charging pump

2.5.4 Boiler temperature control with RVP211, d.h.w. heating with changeover valve

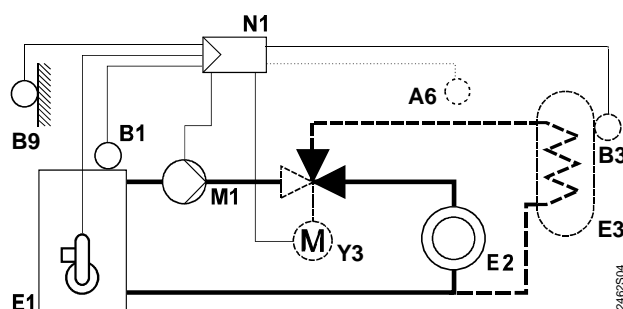

Two-position control, acting on burner, d.h.w. heating with changeover valve

2.5.5 Flow temperature control with RVP211

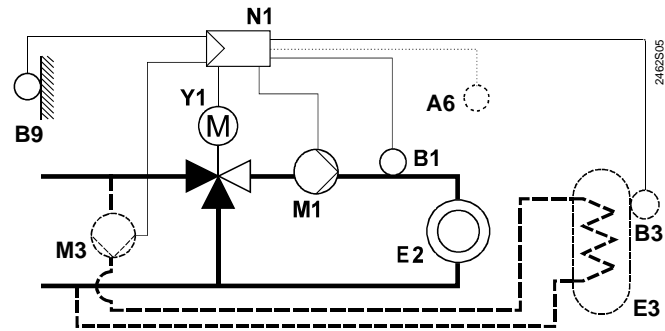

Three-position control, acting on mixing valve; d.h.w. heating with charging pump

- A6 Room unit
- B1 Boiler or flow temperature sensor
- B3 D.h.w. temperature sensor
- B9 Outside sensor
- E1 Heat generating equipment (boiler)
- E2 Load (room)
- E3 D.h.w. storage tank
- M1 Heating circuit pump
- M3 D.h.w. charging pump
- N1 Controller RVP201/211
- Y1 Motorized three- or two-position mixing valve
- Y3 Motorized changeover valve

3 Technical design

3.1 Operating modes

The RVP211 provides the following operating modes:



Automatic operation normal / protection mode

- Automatic changeover between normal temperature and protection mode according to the 24-hour or weekly program
- Automatic d.h.w. heating
- Load-dependent switching on and off of the heating in function of the outside temperature while giving consideration to the building's thermal inertia (ECO automatic energy saver)
- Optional remote operation with the help of a room unit
- Frost protection is ensured



Automatic operation normal / reduced

- Automatic changeover between normal and reduced temperature according to the 24-hour or weekly program
- Automatic d.h.w. heating
- Load-dependent switching on and off of the heating in function of the outside temperature while giving consideration to the building's thermal inertia (ECO automatic energy saver)
- Optional remote operation with the help of a room unit
- Frost protection is ensured



Setback mode

- Continuous heating to the reduced temperature
- Automatic d.h.w. heating
- Load-dependent switching on and off of the heating in function of the outside temperature while giving consideration to the building's thermal inertia (ECO automatic energy saver)
- Frost protection is ensured



Normal mode

- Continuous heating to the normal temperature
- Automatic d.h.w. heating
- No ECO automatic energy saver
- Frost protection is ensured



D.h.w. heating only

- Automatic d.h.w. heating
- Control of heating to protection mode
- Frost protection is ensured



Protection mode

- Heating to the frost protection level
- Frost protection is ensured



Manual operation

- No control
- Heating circuit pump runs
- Control with seat or slipper valve: relay de-energized
Control with burner: boiler always ON
- D.h.w. charging pump runs or d.h.w. changeover valve is deactivated

The RVP201 does not provide  "d.h.w. heating only".

3.2 Acquisition of actual values

3.2.1 General remarks about faults in the measuring circuits

In the event of a faulty temperature sensor, the RVP201/211 always attempts to maintain the required comfort level in the best possible way, even if a certain amount of heat is wasted.

In the case of serious faults that do not allow the RVP201/211 to ensure control, a fault message will be generated. This is indicated on the controller front by the LED which starts flashing when the current operating mode is overridden.

3.2.2 Flow or boiler temperature

Types of sensors

Suitable are all temperature sensors that use a sensing element LG-Ni 1000 Ω at 0 °C:

- Clamp-on temperature sensor QAD22
- Immersion temperature sensor QAE212...
- Immersion temperature sensor QAP21.3 (complete with a ready connected cable)

Handling of faults

If a fault occurs in the control sensor's measuring circuit (short-circuit or interruption), the control switches itself off (mixing valve closes or burner off, heating circuit pump on). In any case, a fault message will be delivered; the LED on the controller front flashes.

3.2.3 Outside temperature

Types of sensors

The following types of outside sensors can be used:

- QAC22 with a sensing element LG-Ni 1000 Ω at 0°C
- QAC32 with a sensing element NTC 575 Ω at 20°C

The controller automatically identifies the type of sensor connected.

Handling of faults

If a fault occurs in the outside sensor's measuring circuit, the control responds as follows:

- Plants with a room temperature sensor:
The controller switches to pure room temperature control
- Plants without a room temperature sensor:

The controller ensures control based on a fix outside temperature of 0 °C

A fault message is generated only when there is no actual value of the room temperature available. This is the case when no room unit is present or when the room temperature measuring circuit is faulty. The LED on the controller front flashes.

3.2.4 Room temperature

Types of sensors

The room temperature is acquired via a PPS (point-to-point interface). Only room units that deliver suitable output signals can be connected to it.

The following types of room units can be used:

- Room unit QAW50
- Room unit QAW70 (room temperature sensor QAW44 can be connected in parallel)

It is also possible to connect an external switch for changeover of the current operating mode to the PPS interface (also refer to "4 Handling"). When the switch is closed, the room temperature cannot be measured.

Handling of faults

Short-circuits or interruptions at the terminals do not trigger fault messages since these statuses have a defined meaning:

Interruption = no room unit connected

Short-circuit = an external switch, if present, is activated

3.2.5 D.h.w. temperature

Types of sensors

The d.h.w. temperature can be acquired with either a sensor or thermostat. For details on the use of a thermostat, refer to "3.7 D.h.w. heating".

Suitable are all temperature sensors with a sensing element LG-Ni 1000 Ω at 0 °C:

- Immersion temperature sensor QAE212...
- Immersion temperature sensor QAP21.3 (complete with a ready connected cable)

Handling of faults

It is not possible to configure whether a sensor or a thermostat is connected. For this reason, a short-circuit or interruption are permitted statuses so that no fault message can be generated.

3.3 Flow or boiler temperature control

3.3.1 Setpoint adjustments

The following manual adjustments are made on the controller:

- Setpoint for the normal temperature. The mid-position of the setting knob's scale corresponds to a setpoint of 20 °C. Readjustments can be made within a range of ± 8 °C, giving a total setting range of 12...28 °C.
- Setback for the reduced temperature. The setting knob's scale represents the setpoint for the normal temperature. The setback is adjustable within a range of 0...-12 °C.

The setpoints of the normal and the reduced temperature are entered directly in °C room temperature. They are independent of whether or not the control uses a room temperature sensor.

The lowest valid room temperature setpoint always represents the minimum setpoint for the frost protection for the plant, even if a lower value has been set as the setpoint for the reduced temperature. The setpoint for the frost protection for the plant is 5 °C (fixed value).

3.3.2 Heating program

The controller has a plug-in type time switch for entering a 24-hour or weekly heating program. For each heating period that uses the normal temperature, the start and end of the period need to be set. Outside of the selected heating periods, the reduced temperature C or protection temperature C will be maintained.

With each type of time switch, several heating phases per day can be set.

In the automatic modes without using a time switch, the lower temperature (reduced or frost protection) will be maintained.

The room unit QAW70 is used to override the heating program. For details, also refer to "6 Mechanical design".

3.3.3 Compensating variables

Outside temperature

The RVP201/211 differentiates between three types of outside temperatures:

- The actual outside temperature (T_A)
- The attenuated outside temperature (T_{AD}). It is generated by filtering the actual outside temperature by the building time constant. This means that compared to the actual outside temperature, the attenuated outside temperature is significantly dampened, thereby representing the long-term development of the outside temperature. The building time constant is a measure of the type of building structure and indi-

ates how quickly the room temperature would change if the outside temperature was abruptly changed. The building time constant has been entered as a fixed value (21 hours). This represents the average building construction, which is the type of building structure where the controller is normally used.

- The composite outside temperature (T_{AM}). It is composed of the two outside temperatures described above, the proportions being as follows:
 - actual outside temperature (T_A) = 75 %
 - attenuated outside temperature (T_{AD}) = 25 %

Using this weighting, the composite outside temperature is less attenuated than the attenuated outside temperature T_{AD} .

In the case of short-time variations of the outside temperature, the composite outside temperature (T_{AM}) prevents the control from responding too quickly.

With weather-compensated control, the RVP201/211 only uses the composite outside temperature.

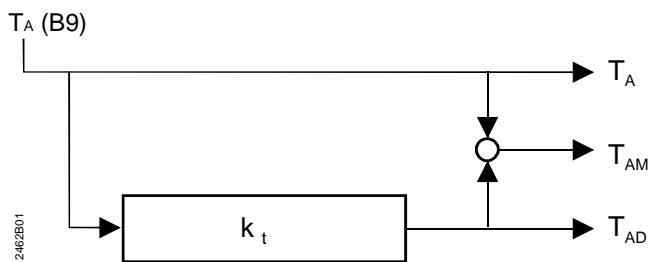

Generation of composite and attenuated outside temperature

T_A Actual outside temperature
 T_{AD} Attenuated outside temperature
 T_{AM} Composite outside temperature
 k_t Building time constant

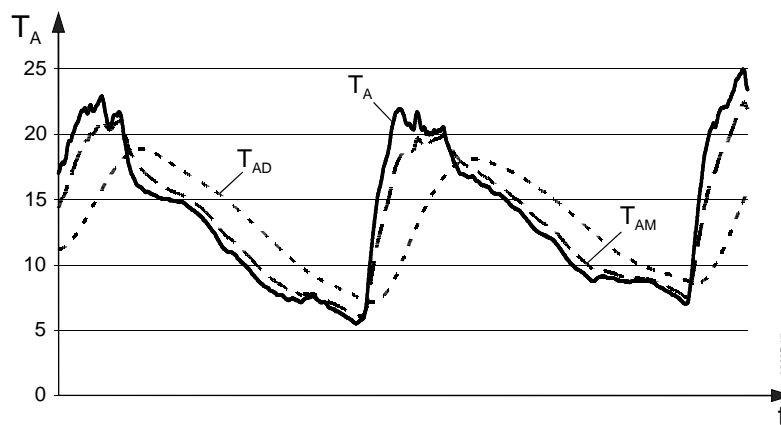

Development of actual, composite and attenuated outside temperature

T_A Actual outside temperature
 T_{AD} Attenuated outside temperature
 T_{AM} Composite outside temperature
 t Time

Room temperature

The control considers the room temperature as follows:

- With room temperature-compensated flow temperature control, the deviation of the actual room temperature from the room temperature setpoint is the only compensating variable
- With weather-compensated control with room temperature influence, the deviation is an additional compensating variable

The gain factor for the influence of the room temperature can be adjusted. This factor indicates to what extent a room temperature deviation will change the room temperature setpoint, thereby acting indirectly (via the heating curve slope) on the flow temperature control:

0 %, Off = room temperature deviation has no impact on the setpoint generation
 100 % = maximum impact of room temperature deviation on the setpoint generation
 This function requires a room temperature sensor (room unit).

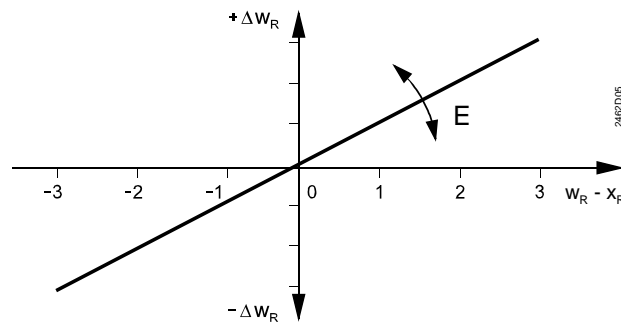

Gain factor of room temperature deviation

- ΔW_R Decrease of room temperature setpoint
- + ΔW_R Increase of room temperature setpoint
- E Authority
- $W_R - X_R$ Setpoint minus actual value (room temperature)

The change ΔW_R of the room temperature setpoint is calculated in a static state using the following formula:

$$\Delta W_R = \frac{\text{Gain factor [\%]}}{10} \times (W_R - X_R)$$

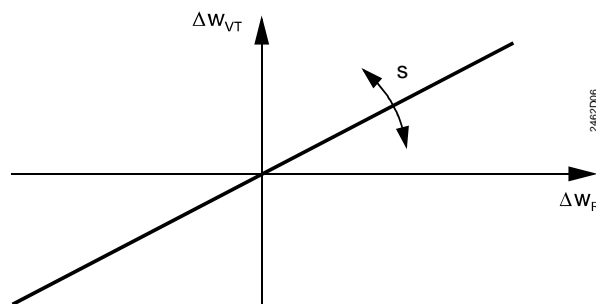

Impact of change of room temperature setpoint on the flow temperature setpoint

- ΔW_R Change of room temperature setpoint
- s Slope of heating curve
- ΔW_{VT} Change of flow temperature setpoint

The change ΔW_{VT} of the flow temperature setpoint is calculated using the following formula:

$$\Delta W_{VT} = \Delta W_R \times (s + 1)$$

3.3.4 Heating curve chart

General, basic setting

With weather-compensated flow temperature control (with or without room temperature influence), the heating curve assigns the flow temperature setpoint to the prevailing outside temperature. The heating curve slope is set with a setting knob on the front of the controller.

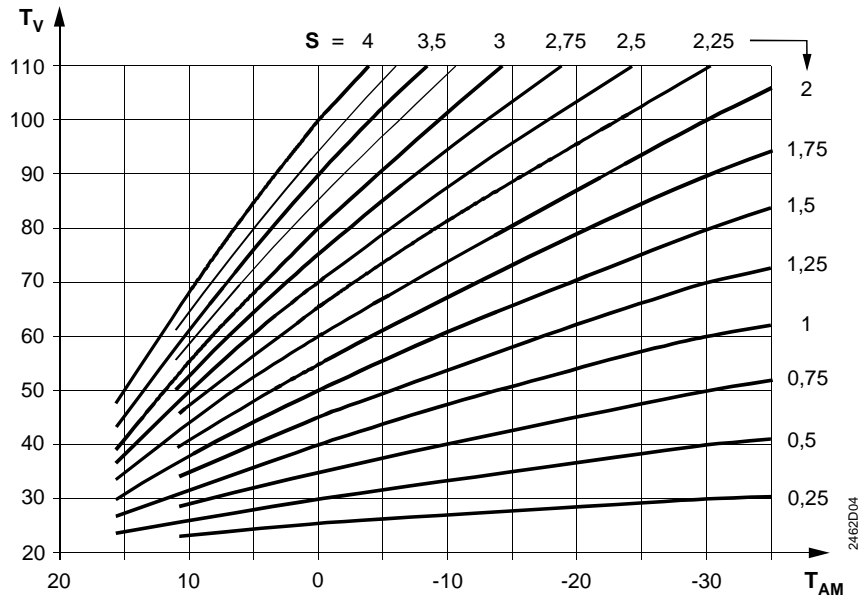

Heating curve chart

- S Slope
- T_{AM} Composite outside temperature
- T_V Flow temperature

The heating curve has a fixed tilting point at an outside temperature of 22 °C and a flow temperature of 20 °C. The heating curve slope can be infinitely set around this point in the range 0.25...4.

The substitute line of each heating curve runs through the tilting point and intersects "its" heating curve at an outside temperature of 0 °C. Its slope is calculated as follows: $s = \Delta T_V : \Delta T_{AM}$ and is adjusted on the controller.

The substitute lines are needed because the heating curve is slightly inflected. This is required to compensate for the non-linear characteristics of the different types of radiators and convectors.

The basic setting is to be made in agreement with the planning documentation or according to local practices.

The heating curve is based on a room temperature setpoint of 20 °C.

3.3.5 Generation of setpoint

Weather-compensated control

The setpoint is generated via the heating curve based on the **composite** outside temperature.

Without room unit

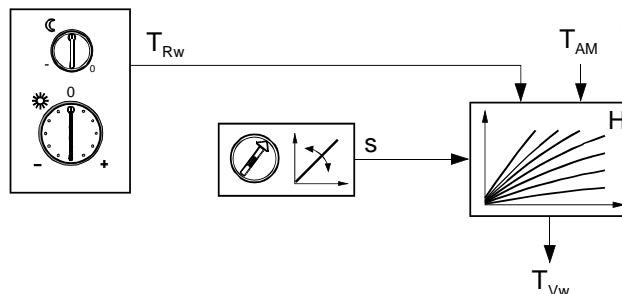

Generation of setpoint with weather-compensated control, without a room unit

- H Heating curve
- s Slope of heating curve
- T_{AM} Composite outside temperature
- T_{Rw} Room temperature setpoint
- T_{Vw} Flow temperature setpoint

With authority of room temperature deviation

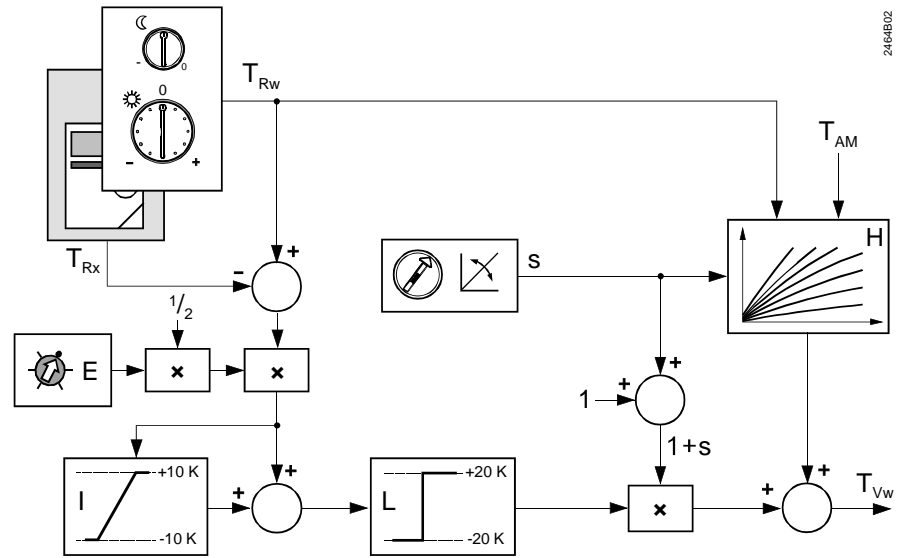

2464B02

Generation of setpoint with weather-compensated control, with authority of room temperature deviation

- x Multiplier
- E Authority (gain factor) of room temperature deviation
- H Heating curve
- I Integrator with limitation
- L Limiter
- s Slope of heating curve
- T_{AM} Composite outside temperature
- T_{Rw} Room temperature stepping
- T_{Rx} Room temperature
- T_{Vw} Flow temperature setpoint

Room temperature-compensated control

The setpoint is generated based on the setpoint / actual value deviation of the room temperature. Also, the heating curve slope with a fixed outside temperature of 0 °C is taken into account. The generation of this factor corresponds exactly to the generation of the flow temperature setpoint in the case of weather-compensated control with or without room temperature influence.

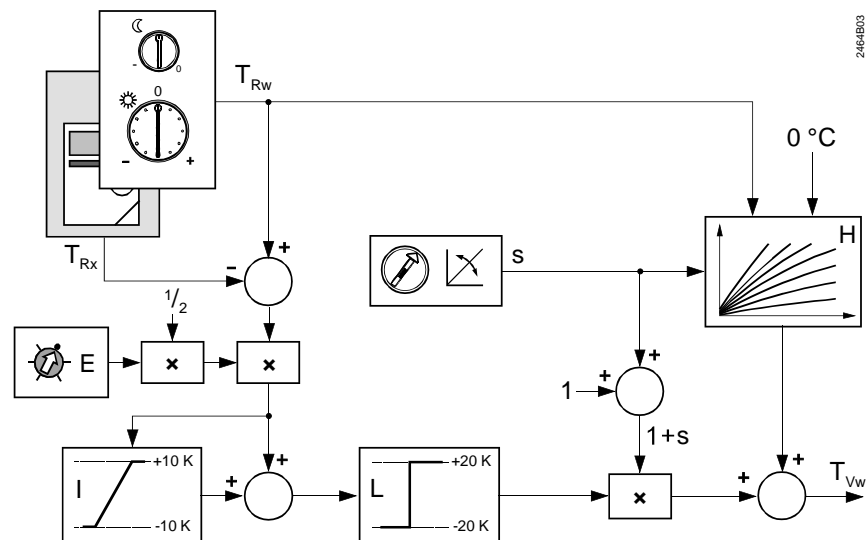

2464B03

Generation of setpoint with room temperature-compensated control

- x Multiplier
- E Authority (gain factor) of room temperature deviation
- H Heating curve
- I Integrator with limitation
- L Limiter
- s Slope of heating curve
- T_{Rw} Room temperature setpoint
- T_{Rx} Room temperature
- T_{Vw} Flow temperature setpoint

3.3.6 Control

Weather-compensated control

Prerequisites for this type of control

- Outside sensor connected
- No room unit connected, **or**
- Room authority set to 0 % or to Off if a room unit is connected

The compensating variable used for weather-compensated control is the composite outside temperature. Assignment of the flow temperature setpoint to the compensating variable is made via the selected heating curve. The room temperature is not taken into consideration. This type of control is used primarily in plants or buildings where

- several rooms are occupied at the same time
- no room is suited as a reference room for the room temperature

Room temperature-compensated control

Prerequisites for this type of control:

- Room unit connected
- No outside sensor connected, **or**
- Room authority set to 100 % if an outside sensor is connected

If no outside sensor is connected, the setting potentiometer for the room authority is inactive.

The compensating variable used for room temperature-compensated control is the setpoint / actual value deviation of the room temperature. The room authority is generated based on this deviation. Also, an outside temperature of 0 °C is assumed and taken into account when generating the setpoint.

- When there is no temperature deviation in the room, the controller maintains the flow temperature setpoint resulting from
 - 0 °C outside temperature, and
 - the selected heating curve slope
- Any room temperature deviation produces an instant parallel displacement of the selected heating curve. The correlation between the extent of temperature deviation and the degree of displacement is defined by the room authority, which is dependent on
 - the setpoint / actual value deviation of the room temperature
 - the selected heating curve slope

The purpose of room influence is to enable the controller to exactly reach and maintain the respective setpoint.

This type of control provides PI control during the control process, the I-part ensures that the required room temperature will be reached and maintained with no offset. .

This type of control is used primarily in plants or buildings where a room is suited as a reference room for the room temperature.

Weather-compensated control with room influence

Prerequisites for this type of control:

- Outside sensor connected
- Room unit connected
- Room authority set in the range 0...100 %

The compensating variables used for weather-compensated control with room influence are:

- The composite outside temperature
- The setpoint / actual value deviation of the room temperature

The setpoint of the flow temperature is continuously shifted in function of the composite outside temperature (via the heating curve). Also, any room temperature deviation produces an instant parallel displacement of the heating curve. The correlation between the extent of the temperature deviation and the degree of displacement is defined by the room authority, which is dependent on

- the selected authority
- the setpoint / actual value deviation of the room temperature
- the selected heating curve slope

These three factors are used to generate the corrective variable for the flow temperature setpoint.

This type of control is used primarily in well insulated buildings or buildings with considerable heat gains where

- several rooms are occupied at the same time
- a room is suited as a reference room for the room temperature

3.3.7 Control process

Three-position flow temperature control

If the flow temperature deviates from the setpoint, a two-port seat valve or mixing valve (three-port seat or slipper valve) driven by an electric actuator is controlled in a step-wise fashion until the setpoint is reached.

The RVP201/211 is suited to drive electric or electro-hydraulic actuators with a running time of 2 to 3 minutes, whereby a maximum running time of 6 minutes may not be exceeded.

Two-position flow temperature control

If the flow temperature deviates from the setpoint, a two- or three-port seat valve driven by an electro-thermal actuator is controlled in on / off mode until the setpoint is reached. The switching differential is constant at 1 K (fixed value).

The RVP201/211 is suited to drive electro-thermal actuators with a running time of 8 to 16 minutes.

Two-position boiler temperature control

Two-position control maintains the required boiler temperature by switching the burner on and off. The control commands to the burner are delivered via the output relay.

The minimum running time of the burner is 4 minutes (fixed value). The switching differential is adjustable in the range 1...20 K.

The controller compares the actual value of the boiler temperature with the setpoint. If the boiler temperature falls below the setpoint by an amount equal to half the switching differential, the burner is switched on. If the boiler temperature exceeds the setpoint by half the switching differential, the burner is switched off again.

If there is no more deviation before the minimum burner running time has elapsed, the burner will still remain switched on until that time has elapsed (burner cycling protection). This means that the minimum burner running time has priority. To be considered is the boiler temperature's maximum limitation however, which always switches the burner off.)

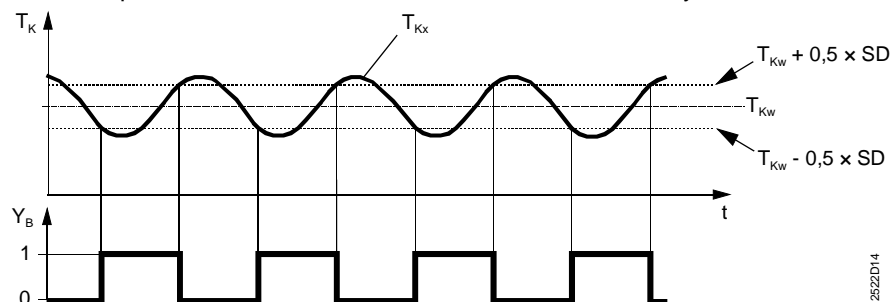

SD Switching differential
t Time
TK Boiler temperature
wTK Boiler temperature setpoint
xTK Boiler temperature actual value
YB Burner control signal

Frost protection for the boiler

Frost protection for the boiler uses fixed values:

- Switch-on point: 5 °C boiler temperature (= minimum limit value)
- Switch-off point: minimum limit value of boiler temperature + switching differential.

For the switching differential, the value set for control will be adopted. During quick setback or when there is no demand for heat, the boiler will be shut down, that is, no defined minimum temperature will be maintained.

If, however, the boiler temperature falls below 5 °C, the burner will always be switched on until the boiler temperature has exceeded the minimum limit value of the boiler temperature by the amount of the switching differential. This always ensures a minimum boiler temperature of 5 °C.

3.3.8 Limitations

Note

The maximum limitations are no safety functions! For this purpose, devices such as thermostats, limit thermostats, etc., are to be used.

Maximum limitation of flow temperature

Maximum limitation of the flow temperature can be set in the range 10...100 °C. At the limit value, the heating curve runs horizontal. This means that the flow temperature setpoint cannot exceed the maximum value. This function can be disabled.

Maximum limitation of boiler temperature

Maximum limitation of the boiler temperature can be set in the range 10...100 °C. The burner's switch-off point cannot be higher than the maximum limit value. In that case, the switch-on point will be lower by the amount of the set switching differential. This function can be disabled.

Minimum limitation of boiler temperature

For minimum limitation of the boiler temperature, a fixed limit value of 5 °C has been entered. The switch-on point cannot fall below the minimum limit value. In that case, the switch-off point will be higher by the amount of the set switching differential (also refer to "Frost protection for the boiler" in section "3.3.7 Control process").

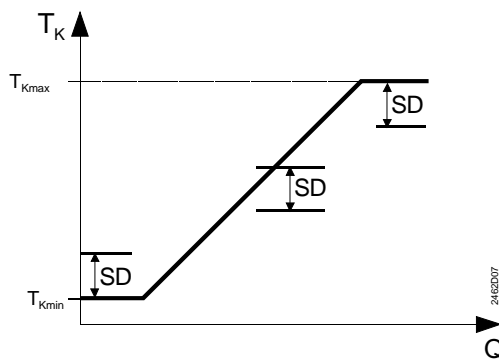

Action of switching differential at the limit values

Q_H Heating load
 SD Switching differential
 T_K Boiler temperature
 T_{Kmax} Maximum limit value
 T_{Kmin} Minimum limit value

3.4 Optimization functions

3.4.1 Boost heating

When changing from a lower temperature level (reduced temperature or protection mode) to the normal temperature, the room temperature setpoint is raised by 5 K, also leading to an appropriately higher flow temperature setpoint. Also, the selected room authority is considered when generating this setpoint.

The boost of 5 K is factory-set.

When the room temperature is only 0.25 K below the normal temperature setpoint, the boost function will be disabled.

Boost heating can be provided only if a room temperature sensor (room unit) is used. It is active independent of the setting of potentiometer E.

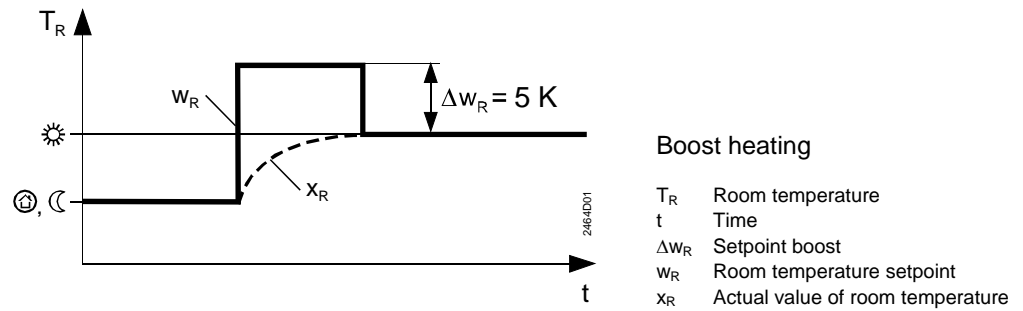

3.4.2 Quick setback

When changing from the normal temperature to a lower level (reduced temperature or protection), the heating will be shut down (mixing valve closes or burner off, heating circuit pump off), and it remains shut down until the room temperature has reached the setpoint of the lower temperature level. Then, the heating switches on again and maintains the current setpoint.

Quick setback can be provided only if a room temperature sensor (room unit) is used. This function can be deactivated with the setting potentiometer E (position Off).

3.5 ECO automatic energy saver

3.5.1 Fundamentals

The ECO automatic energy saver controls the heating depending on demand. It takes into account the building construction-dependent behavior of the room temperature when the outside temperature changes. If the amount of heat stored in the building is sufficient to maintain the current room temperature setpoint, the heating will be shut down (mixing valve closes or burner off, heating circuit pump off).

In the RVP201/211, the ECO automatic energy saver is subdivided into two part functions. ECO function 1 is used predominantly in the summer while ECO function 2 responds primarily to short-term temperature variations and is therefore active during intermediate seasons.

Operation of the ECO automatic energy saver is dependent on the operating mode:

Operating mode	ECO
Automatic mode	Active
Automatic mode	Active
Normal mode	Inactive
Setback mode	Active
Protection mode	Active
Manual operation	Inactive
D.h.w. heating only (only with RVP211)	Inactive

ECO automatic energy saver active means:

- Seat or slipper valve closed or burner off
- Heating circuit pump switched off (it can only be activated by frost protection for the plant)

Owing to the ECO automatic energy saver, the heating operates only or consumes energy only if really required.

If desired, the ECO automatic energy saver can be deactivated.

3.5.2 Compensating and auxiliary variables

Note

Also refer to "3.3.3 Compensating variables".

The ECO automatic energy saver necessitates an outside sensor. As compensating and auxiliary variables, it takes into account the development of the outside temperature and the building's heat storage capacity. The following parameters are considered:

- the building's time constant
- the actual outside temperature (T_A)
- the attenuated outside temperature (T_{AD}). Compared to the actual outside temperature, the attenuated outside temperature is significantly dampened.

This ensures that no heating will be provided in the summer by making certain that the heating will not be switched on during a few cool days

- the composite outside temperature (T_{AM}). Since the composite outside temperature is attenuated, it represents the impact of short-term variations of the outside temperature on the room temperature as they often occur during intermediate seasons (spring and autumn)

By considering the attenuated outside temperature, the ECO automatic energy saver takes into account the thermal inertia of the building should temperature variations occur.

3.5.3 Heating limit

The ECO automatic energy saver requires a heating limit to set an ECO temperature in the range $-10...+8$ K. From this setting value and the room temperature setpoint, the heating limit is calculated.

3.5.4 Mode of operation of ECO function 1

ECO function 1 operates as an automatic summer / winter switch. The heating will be switched off (mixing valve closes or burner off, heating circuit pump off) when the attenuated outside temperature exceeds the heating limit.

It is switched on again as soon as all three outside temperatures have fallen below the heating limit by an amount equal to the switching differential.

The heating limit is determined as follows:

Heating limit = $w_N + T_{ECO}$ (normal setpoint plus ECO temperature)

Example

A room temperature setpoint w_N of $+20$ °C and an ECO temperature T_{ECO} of -5 K give a heating limit of $+15$ °C.

3.5.5 Mode of operation of ECO function 2

ECO function 2 operates as an automatic 24-hour limit switch. The heating will be switched off (mixing valve closes or burner off, heating circuit pump off) when the actual **or** the composite outside temperature exceeds the heating limit.

It is switched on again as soon as all three outside temperatures have fallen below the heating limit by an amount equal to the switching differential.

The heating limit is determined as follows:

Heating limit = $w_{akt} + T_{ECO}$ (current setpoint plus ECO temperature)

In contrast to ECO function 1, it is taken into consideration here when a reduced temperature level is maintained.

Example

A room temperature setpoint w_{akt} of $+18$ °C and an ECO temperature T_{ECO} of -5 K give a heating limit of $+13$ °C.

In the case of protection mode, the ECO function does not use a setpoint, but a fixed value. Also, the heating limit has a minimum limitation. It cannot be lower than 2 °C.

The heating limit is determined as follows:



$5 + T_{ECO}$ (fixed value of 5 °C plus ECO temperature)

3.6 Frost protection for the plant and the building

3.6.1 Frost protection for the plant

Frost protection for the plant provides protection against freezing by activating the heating circuit pump, if controller and heat generating equipment are ready to operate (mains voltage present).

Frost protection for the plant can be provided with or without an outside sensor. The switching differential is 1 K (fixed value).

Frost protection is always active, even if the control is switched off (operating modes ) and ) , with quick setback, and with Off through ECO.

If desired, frost protection for the plant can be deactivated with the coding switch "Frost protection".

With outside sensor

Frost protection for the plant is accomplished in two steps:

1. If the outside temperature falls to 1.5 °C, the heating circuit pump will be activated for 10 minutes at 6-hour intervals.
2. If the outside temperature falls to -5 °C, the heating circuit pump will be activated and runs continuously.

The frost protection stage active at a time will be switched off when the outside temperature has exceeded the limit value by an amount equal to the switching differential of 1 K.

Without outside sensor

Frost protection for the plant is accomplished in two steps:

1. If the flow temperature falls to 10 °C, the heating circuit pump will be actuated for 10 minutes at 6-hour intervals.
2. If the flow temperature falls to 5 °C, the heating circuit pump will be actuated and runs continuously.

The frost protection stage active at a time will be switched off when the flow temperature has exceeded the limit value by an amount equal to the switching differential of 1 K.

3.6.2 Frost protection for the building

Frost protection for the building protects the rooms from excessively low temperatures. It acts in all operating modes as a minimum limitation of the room temperature. It can be achieved with or without room unit, provided the heating curve slope is correctly set. The frost protection for the building is given higher priority over the ECO automatic energy saver. If desired, frost protection for the building can be deactivated with the coding switch "Frost protection".

- Without room unit:
 - Attenuated outside temperature ≤ 5 °C: the control is switched on and the flow temperature is controlled such that a room temperature of 5 °C will be maintained
 - Attenuated outside temperature >6 °C: the control is switched off
- With room unit and with quick setback active:
 - Room temperature ≤ 5 °C: the control is switched on and the flow temperature is controlled such that a room temperature of 5 °C will be maintained
 - Room temperature >6 °C: the control is switched off
- With room unit, but without quick setback:
 - Same as without room unit

3.7 D.h.w. heating

3.7.1 General

Only the RVP211 provides d.h.w. heating. It supports operation with the charging pump or the changeover valve.

For d.h.w. heating, the RVP211 features:

- a fourth output relay (Q3) for the control of the d.h.w. charging pump or the d.h.w. changeover valve
- a setting facility for the d.h.w. temperature setpoint
- a setting facility for the priority

3.7.2 Acquisition of d.h.w. temperature

Refer to "3.2 Acquisition of actual values".

The d.h.w. temperature can also be acquired with a thermostat, at the expense of reduced functionality, however.

Since all measuring circuits use low voltage, an intermediate relay is required. The thermostat controls the relay whose contacts are connected to terminals B3-M (also refer to "5.2 Connection diagrams").

On the thermostat, the setpoint of the d.h.w. temperature is set. If the d.h.w. temperature falls below the setpoint, the thermostat will energize the relay, and the controller interprets the bridging of terminals B3-M as a demand for d.h.w. heating.

Alternative to the relay: if a **new** thermostat is used, or a thermostat with **new contacts**, the intermediate relay will not be required.

The contacts of the thermostat must meet the following requirements, however:

- Transfer resistance $<80 \Omega$
- Voltage $<10 \text{ V}$
- Current $\leq 10 \text{ mA}$

The contacts must be capable of switching reliably the required voltage and current.

3.7.3 D.h.w. heating with charging pump

D.h.w. heating with a charging pump can be employed either with mixing valve operation (flow temperature control) or boiler operation (boiler temperature control).

To ensure fast d.h.w. heating, the other heating loads can be restricted during the time the d.h.w. is heated (priority). The following choices are available:

- Absolute priority:
During d.h.w. heating, the heating circuit pump is locked, which means that all other heating loads will be dead.
In the case of underfloor or ceiling heating systems, as well as boiler operation, absolute priority is mandatory
- No priority (parallel operation):
Both heating circuit pump and charging pump operate at the same time

If the sensor acquires a d.h.w. temperature that lies 5 K below the d.h.w. temperature setpoint (or if the contact of the d.h.w. thermostat closes), the charging pump will be activated. During d.h.w. heating, the flow temperature is raised to a level that is 16 K (fixed value) higher than the adjusted setpoint of the d.h.w. temperature.

When the d.h.w. temperature reaches the setpoint, the charging pump will be deactivated again. If the d.h.w. temperature falls to a level that lies 5 K below the setpoint (switching differential), the charging pump will be activated again.

Enabling of d.h.w. heating:

Measurement with a sensor

Measurement with a thermostat

Priority

Heating

D.h.w. heating is always enabled; there are no locking times.
 In manual operation, d.h.w. heating is switched on; the charging pump is enabled.

Switching differential

With d.h.w. heating (charging pump or changeover valve), the switching differential lies asymmetrically below the setpoint:

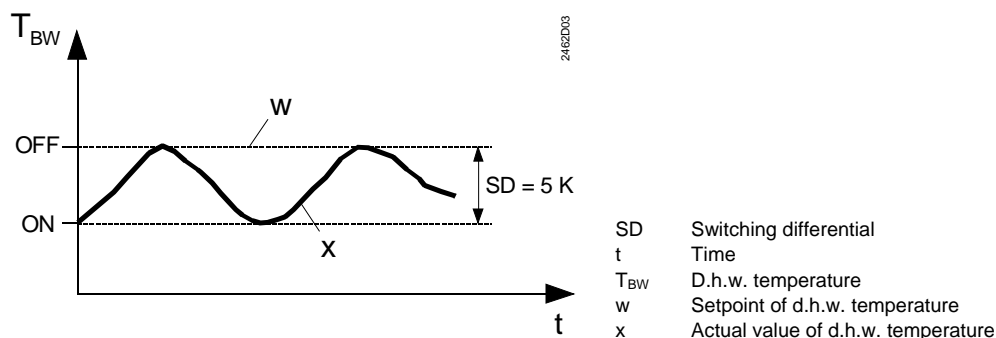

Protection against discharging

If, in the case of boiler operation, the boiler temperature during the pump overrun time lies below the d.h.w. temperature, pump overrun will be stopped prematurely (that is, before the 6 minutes have elapsed). This prevents the d.h.w. from cooling down unnecessarily.

When using a thermostat for the d.h.w. temperature, pump overrun will be stopped when the boiler temperature lies below the adjusted d.h.w. temperature setpoint.

3.7.4 D.h.w. heating with changeover valve

Heating

If the sensor acquires a d.h.w. temperature that lies 5 K below the d.h.w. temperature setpoint (or if the contact of the d.h.w. thermostat closes), the changeover valve will be activated. During d.h.w. heating, the flow temperature is raised to a level that is 16 K (fixed value) higher than the adjusted setpoint of the d.h.w. temperature. When the d.h.w. temperature reaches the setpoint, the changeover valve will be shut down again. D.h.w. heating is always enabled; there are no locking times.

In manual operation, d.h.w. heating is switched off; the changeover valve travels to the position "Heating circuit" (space heating).

Protection against discharging

If, in the case of boiler operation, the boiler temperature during the pump overrun time lies below the d.h.w. temperature, pump overrun will be stopped prematurely (that is, before the 6 minutes have elapsed). This prevents the d.h.w. from cooling down unnecessarily.

When using a thermostat for the d.h.w. temperature, pump overrun will be stopped when the boiler temperature lies below the adjusted d.h.w. temperature setpoint.

3.7.5 Frost protection

The d.h.w. storage tank is protected against frost, provided a d.h.w. temperature sensor is used.

Frost protection is automatically activated if the d.h.w. temperature falls below 5 °C.

The charging pump or the changeover valve will be activated and a d.h.w. temperature of at least 5 °C is maintained.

Caution!

When using a thermostat, the RVP211 **does not** provide frost protection for the d.h.w. storage tank.

3.8 Pump control

The controller controls the heating circuit pump depending on demand. This means that the pump will be switched on only when there is demand for heat or when frost protection for the plant has responded.

3.8.1 Pump overrun

To ensure there is no buildup of heat in the boilers (overtemperature protection), heating circuit pump and charging pump continue to run for a certain period of time after the switch-off command has been given. The factory-set pump overrun time is 6 minutes. Depending on the type of plant and the operational status, overrun of the heating circuit pump and the charging pump acts as follows:

Type of plant	Priority	Operation	Heating circuit or boiler pump	Charging pump or changeover valve
Boiler operation	Absolute	D.h.w. heating only ¹⁾	Off	Overrun ⁵⁾
D.h.w. heating with charging pump	Absolute	D.h.w. heating + Q_H ²⁾	Off → On ⁴⁾	Overrun ⁵⁾
		$Q_H \rightarrow 0$ ³⁾	Overrun	Off
Boiler operation	–	D.h.w. heating only ¹⁾	Overrun ⁵⁾	Overrun ⁵⁾
D.h.w. heating with changeover valve	–	D.h.w. heating + Q_H ²⁾	On	Overrun ⁵⁾
		$Q_H \rightarrow 0$ ³⁾	Overrun ⁵⁾	–
Mixing valve operation	Absolute or parallel	D.h.w. heating only ¹⁾	Off	No Overrun
	Absolute	D.h.w. heating + Q_H ²⁾	On ⁶⁾	No Overrun
	Parallel	D.h.w. heating + Q_H ²⁾	On	No Overrun
	Absolute or parallel	$Q_H \rightarrow 0$ ³⁾	Overrun ⁵⁾	Off

Q_H Heating load

¹⁾ D.h.w. heating only, no space heating (summer operation)

²⁾ D.h.w. heating and, at the same time, normal heating operation (heating season)

³⁾ No heating load (Off by ECO)

⁴⁾ On completion of d.h.w. heating, the heating circuit pump is immediately activated; this may lead to a temperature rise in the heating circuit

⁵⁾ Protection against discharging active



⁶⁾ Mixing valve closes

3.8.2 Pump kick

Periodic pump run is provided to prevent pump seizure during longer off periods (e.g. in the summer). After the last regular use of the pump, the pump kick is provided for one minute at 156-hour intervals.

3.9 Interactions with room units

3.9.1 General

- Room units can act on the RVP201/211 only if the controller works in one of the two automatic modes  or 
- The room temperature acquired by a room unit is adopted by the RVP201/211 at terminal A6. If the room temperature acquired by the room unit shall not be considered by the control functions, the room authority must be set to 0 %. In that case, all the other room unit functions will be maintained
- If an inadmissible room unit is connected, the RVP201/211 decides that a fault has occurred and the room unit will be switched to a passive state, which means that any actions performed on the room unit have no effect

3.9.2 Interactions with room unit QAW50



Room unit QAW50 with room temperature sensor and room temperature readjustment (setting knob)

The QAW50 can act on the RVP201/211 in the following manner:

- Overriding of the operating mode
- Readjustment of the room temperature

For this purpose, the QAW50 has three operating elements:







- Operating mode slider
- Economy button (also called presence button)
- Setting knob for room temperature readjustments

Overriding the operating mode

From the QAW50, the current operating mode of the RVP201/211 can be overridden. This is accomplished with the operating mode slider and the economy button. To enable the QAW50 to act on the controller, the latter must meet the following operating conditions:

- Automatic mode
- A6–MD not bridged (that is, external changeover switch, if present, must be open)

The actions of the QAW50 operating mode slider on the RVP201/211 are as follows:

Operating mode QAW50	Operating mode RVP201/211
	Automatic mode  or  ; temporary overriding with QAW50 economy button possible
	Normal or setback mode, depending on economy button, permanent overriding
	Protection mode 

Setting knob

With the setting knob of the QAW50, only the room temperature setpoint of normal heating can be readjusted by a maximum of ± 3 °C. This readjustment is added to the setting made on the RVP201/211.

3.9.3 Interactions with room unit QAW70



Room unit QAW70 with room temperature sensor, time switch, setpoint adjustment and room temperature readjustment (setting knob)

With the QAW70, the following functions can be provided and actions on the RVP201/211 effected:

- Overriding of operating mode
- Overriding of room temperature setpoints
- Overriding of d.h.w. temperature setpoint
- Readjustment of room temperature
- Entry of weekday and time of day
- Overriding of heating program of RVP201/211 time switch
- Display of actual values acquired by the RVP201/211 time switch

For this purpose, the QAW70 has the following operating elements:







- Operating mode buttons
- Economy button (also called presence button)
- Setting knob for room temperature readjustments
- Buttons for selecting the operating lines
- Buttons for adjusting the values

Overriding the operating mode

From the QAW70, the current operating mode of the RVP201/211 can be overridden. This is accomplished with the operating mode buttons and the economy button. To enable the QAW70 to act on the controller, the latter must meet the following operating conditions:

- Automatic mode
- A6–MD not bridged (that is, external changeover switch, if present, must be open)

The actions of the QAW70 operating mode buttons on the RVP201/211 are as follows:



Operating mode QAW70	Operating mode RVP201/211
	Automatic mode  or  ; temporary overriding with QAW70 economy button possible
	Normal or setback mode, depending on economy button, permanent overriding
	Protection mode 

Setting knob

With the setting knob of the QAW70, only the room temperature setpoint of normal heating set on operating line 1 can be readjusted by a maximum of ± 3 °C.

Effects of the QAW70 operating lines

Effects of the individual QAW70 operating lines on the RVP201/211:

<i>Operating line</i>	<i>Function, parameter</i>	<i>Effect on RVP201/211, notes</i>
1	Setpoint of normal heating	Overrides the settings made on the RVP201/211
2	Setpoint of reduced heating	Overrides the settings made on the RVP201/211
3	Setpoint of d.h.w. temperature	Overrides the settings made on the RVP211 (not available with the RVP201)
4	Weekday (entry of heating program)	Valid
5	First heating period, start of normal heating	Overrides the time switch of the RVP201/211
6	First heating period, start of reduced heating	Overrides the time switch of the RVP201/211
7	Second heating period, start of normal heating	Overrides the time switch of the RVP201/211
8	Second heating period, start of reduced heating	Overrides the time switch of the RVP201/211
9	Third heating period, start of normal heating	Overrides the time switch of the RVP201/211
10	Third heating period, start of reduced heating	Overrides the time switch of the RVP201/211
11	Entry weekday 1...7	Overrides the time switch of the RVP201/211
12	Entry time of day	Overrides the time switch of the RVP201/211
13	D.h.w. temperature (with sensor only)	Display only with the RVP211 (not available with the RVP201)
14	Boiler temperature	Display only with the setting  on the RVP201/211
15	Flow temperature	Display only with the setting  on the RVP201/211
16	Annual holidays	RVP201/211 changes to protection mode
17	Reset to default values	QAW70 default values are used

For detailed information about the QAW70 room unit, refer to Installation Instructions 1637 (74 319 0173 0).

4 Handling

4.1 Operation

4.1.1 Operating elements

Operating elements for the user

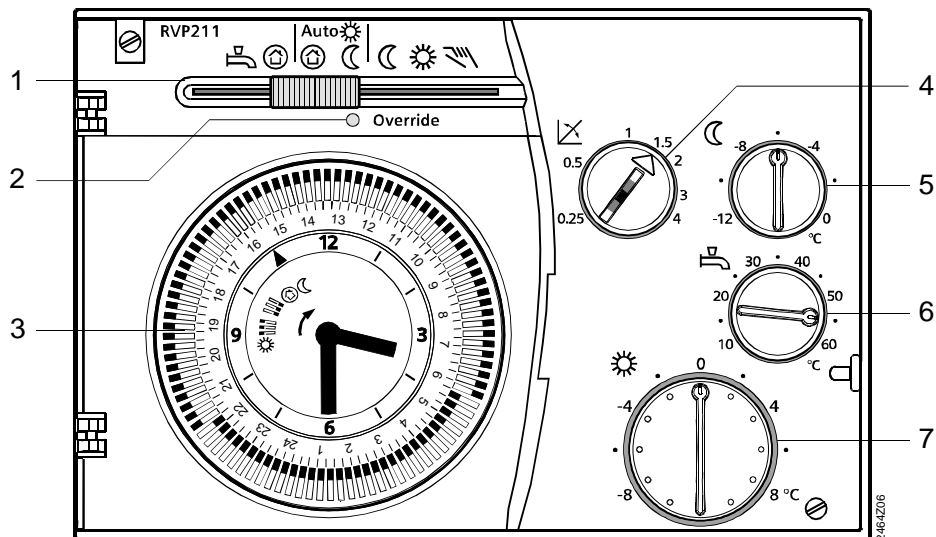



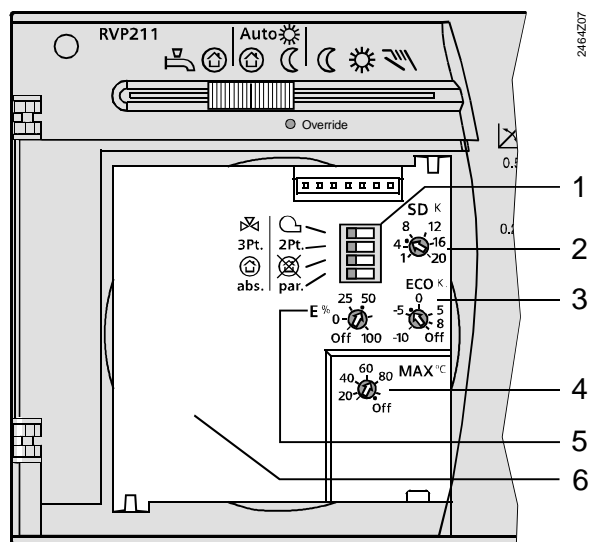

- 1 Slider for selecting the operating mode (the RVP201 does not have the position)
- 2 LED (lit when operating mode is overridden; flashes when a fault is present)
- 3 Time switch
- 4 Setting knob for slope of heating curve
- 5 Setting knob for setback to the reduced temperature
- 6 Setting knob for the d.h.w. temperature (not available with the RVP201)
- 7 Setting knob for the normal temperature; the zero-setting corresponds to a room temperature of 20 °C

Operating elements for the installer



- 1 Coding switches
- 2 Setting potentiometer for the switching differential
- 3 Setting potentiometer for the ECO temperature
- 4 Setting potentiometer for maximum limitation of the flow or boiler temperature
- 5 Setting potentiometer for the authority of the room temperature and quick setback active / inactive
- 6 Space for the time switch

Coding switches

Function	Switch position "left"	Symbol	Switch position "right"	
Type of regulating unit	Control of a motorized seat or slipper valve			Control of a burner (atmospheric or forced draught)
Type of control	Three-position (modulating)	3Pt.	2Pt.	Two-position (on/off)
Frost protection	Yes, frost protection			No, no frost protection
Priority of d.h.w. heating (only with the RVP211)	With priority (absolute). Underfloor heating systems and boiler operation: always use "absolute"!	abs.	par.	No priority (parallel)

RVP211 with boiler temperature control:

Regulating unit for d.h.w. heating	Changeover valve	3Pt.	2Pt.	Charging pump
------------------------------------	------------------	------	------	---------------

Note

In the case of boiler temperature control with the RVP211, coding switch "Type of control" is used for entering the d.h.w. regulating unit.

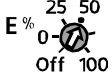
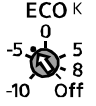
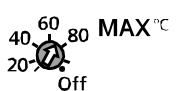

Setting potentiometer

The factory-set value (default value) is marked by a dot ●. This value can be used as a guide value. If no plant-specific settings are available, the factory settings should be used.

Potentiometer	Function	Setting range	Guide values, notes
	Switching differential with two-position control	1...20 K	Effective only with burner control: guide value 6 K
	Effect of room temperature on flow temperature control Quick setback is active/ inactive	0...100 % authority Off	Guide value for plants with outside sensor: 50 % Off = quick setback is inactive
	Heating limit for ECO automatic energy saver	-10...+ 8 K The setting refers to the room temperature setpoint	At 20 °C room temperature, the default value of -3 K gives a heating limit of 17 °C. To disable the function: set to Off
	Maximum limitation of flow or boiler temperature	10...100 °C	Guide value for underfloor and ceiling heating systems: 55 °C max. To disable the function: set to Off

4.1.2 Setting and readjusting the room temperature

To make the basic setting and to readjust the room temperature, there are two setting elements available:

- For setting the heating curve slope, use setting knob 
- For manual readjustment of the room temperature, use setting knob ; its scale gives the room temperature differential in °C; this setting produces a parallel displacement of the heating curve

Recommendations:

- Room temperature is not correct, especially in mild weather:
Readjust the room temperature with setting knob ☼; one graduation corresponds to a room temperature change of about 2 °C
- Room temperature is not correct, especially in cold weather:
Readjust the heating curve slope with setting knob ⚡ :
 - Room temperature too high: reduce slope by about 0.2
 - Room temperature too low: increase slope by about 0.2
- Room temperature is not correct, especially at night:
Readjust the setback with setting knob ☾; its scale gives the setback in °C

4.1.3 Selection of operating mode

The required operating mode is set with the selector on the front of the controller. Also, using an external switch connected to terminals A6-MD, the current operating mode can be overridden from a remote location:

- Contact closed: the controller operates in protection mode
- Contact open: the controller operates in the mode selected with the slider

4.2 Mounting

4.2.1 Mounting location

The controller should be mounted in a dry location, such as the boiler room.

The permissible ambient temperature in operation is 0...50 °C.

The RVP201/211 can be mounted as follows:

- In the control panel, on the inner wall or on a top hat rail
- On a panel front
- In the control panel front
- In the sloping front of a control desk

4.2.2 Mounting methods

The RVP201/211 is designed for three different mounting methods:

- Wall mounting: the base is secured to a flat wall with the help of three fixing screws
- Rail mounting: the base is fitted to the top hat rail
- Flush panel mounting: the base is fitted in a panel cutout measuring 138 × 92 mm

4.2.3 Installation

- Local regulations for electrical installations must be complied with
- The cable lengths should be selected such that the control panel front can be easily opened
- Cable tension relief must be ensured
- The cables of the measuring circuits carry extra low voltage
- The cables from the controller to the regulating unit and to the pumps carry AC 24...230 V mains voltage
- Sensor cables must never be run parallel to mains carrying cables connecting loads such as actuators, pumps, burners, etc. (safety class II to EN60730)
- Maximum limitation of the boiler temperature is not a safety function; for this purpose, a thermostat or limit thermostat must be used and connected to L–F1/F4

5 Engineering

5.1 Connection terminals

5.1.1 Low voltage side

A6	PPS (point-to-point interface) for the connection of the room unit and, if required, for the external switch for operating mode changeover
MD	Ground for the point-to-point interface
B3	Connection for d.h.w. temperature sensor (only with RVP211)
B9	Connection for outside sensor
B1	Connection for flow or boiler temperature sensor
M	Ground for sensors and changeover contact

5.1.2 Mains voltage side

RVP201

L	Phase conductor AC 230 V
N	Neutral conductor AC 230 V
F1/F4	Input for Y1/K4
Y1/K4	Valve OPEN (flow temperature control) or burner ON (boiler temperature control)
F2	Input for Y2
Y2	Valve CLOSED (flow temperature control)
F3	Input for Q1
Q1	Heating circuit pump ON

RVP211

L	Phase conductor AC 230 V
N	Neutral conductor AC 230 V
F1/F4	Input for Y1/K4
Y1/K4	Valve OPEN (flow temperature control) or burner ON (boiler temperature control)
F2	Input for Y2
Y2	Valve CLOSED (flow temperature control with three-position actuator)
F3	Input for Q1 and Q3/Y3
Q1	Heating circuit pump ON
Q3/Y3	D.h.w. charging pump or changeover valve ON

5.1.3 Auxiliary terminals

In addition to the standard connection terminals, the base accommodates three auxiliary terminals: M; N and .

5.2 Connection diagrams

5.2.1 Low voltage side

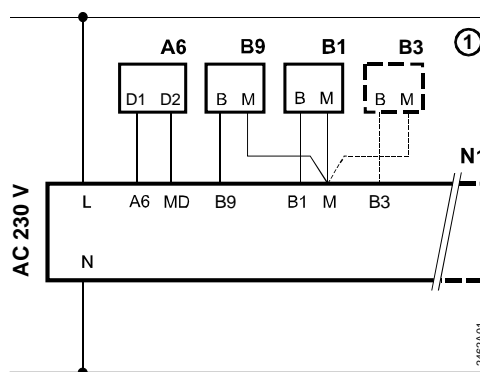

Measurement of d.h.w. temperature with a sensor (only with RVP211)

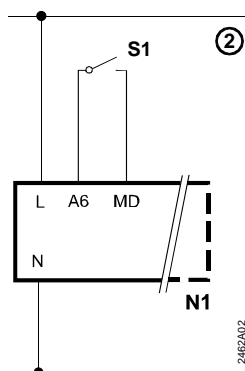

External switch for changeover of operating mode (can also be connected in parallel with the room unit)

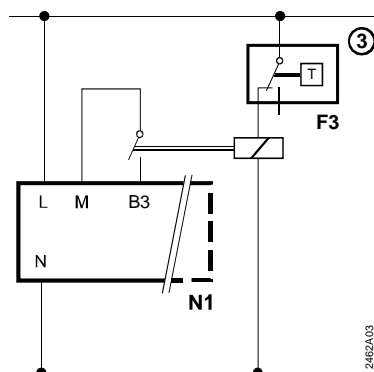

Measurement of d.h.w. temperature with a thermostat and an intermediate relay (only with RVP211)

- A6 Room unit
- B1 Flow or boiler temperature sensor
- B3 D.h.w. temperature sensor (with RVP211 only)
- B9 Outside sensor
- F3 D.h.w. thermostat (only with RVP211)
- N1 Controller RVP201/211
- S1 External switch for changeover of operating mode

5.2.2 Mains voltage side

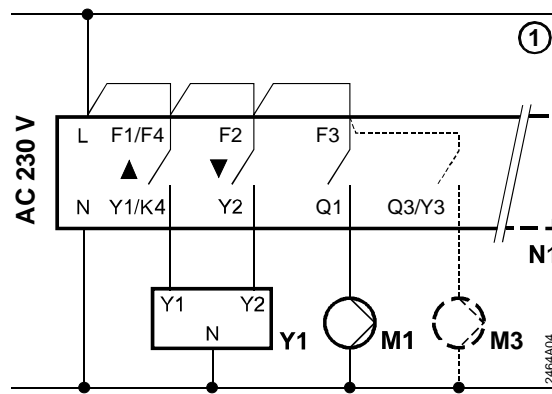

Connection of three-position actuator (flow temperature control), heating circuit pump and d.h.w. charging pump (charging pump only with RVP211)

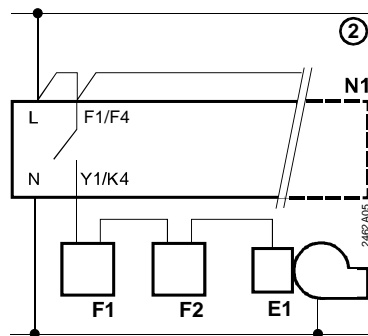

Connection of burner (boiler temperature control)

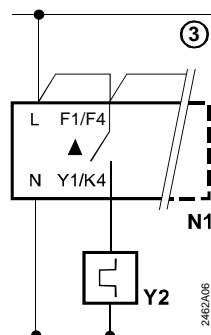

Connection of two-position actuator (flow temperature control)

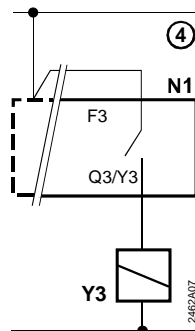

Connection of actuator for changeover valve (only with RVP211)

- E1 Burner
- F1 Thermal reset limiter thermostat
- F2 Manual reset safety limit thermostat
- M1 Heating circuit pump
- M3 D.h.w. charging pump (only with RVP211)
- N1 Controller RVP201/211
- Y1 Three-position actuator
- Y2 Two-position actuator
- Y3 Actuator for d.h.w. changeover valve (only with RVP211)

6 Mechanical design

6.1 Controller

6.1.1 Basic design

The RVP201/211 is comprised of controller insert, which houses the electronics, the power section, the output relays and all operating elements (on the controller front), and the base, which carries the connection terminals. The operating elements are located behind a transparent cover. At the rear of the cover, there is a slot where the operating instructions can be inserted. The cover can be sealed.

The time switch is of plug-in design. The coding switches and setting potentiometers for the plant-specific settings can be accessed after removal of the time switch.

If the controller is used without a time switch (RVP201.0 or RVP211.0), the space for the time switch is covered up with a hinged cover. If a time switch is fitted at a later time, the appropriate hole in the cover must be cut out with a knife.

The RVP201/211 can be fitted in three different ways:

- Wall mounting
- Rail mounting
- Flush panel mounting; in that case, the front panel may have a maximum thickness of 3 mm

To make certain the controller will be mounted the correct way, both base and casing of the controller insert are marked "TOP".

First, the base is fitted and wired up. Then, the controller insert is secured to the base by means of two screws. The fixing screw at the top can be sealed: screw the plug (to be ordered as a separate item) into the threaded hole, insert a sealing wire through the two lugs and seal it.

6.1.2 Dimensions

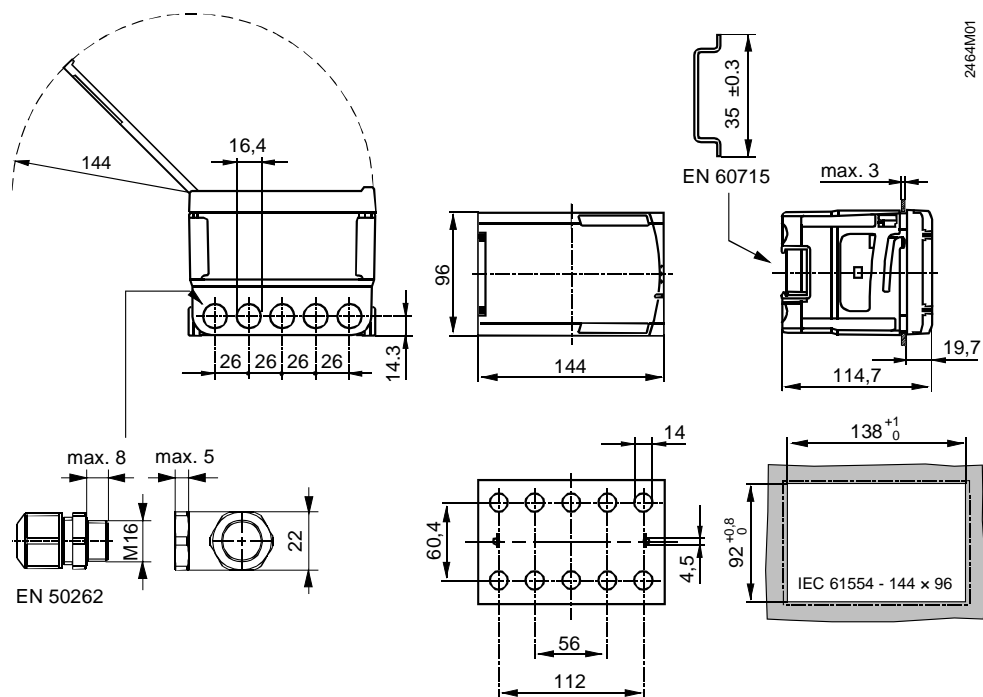

Dimensions in mm

6.1.3 Outside view

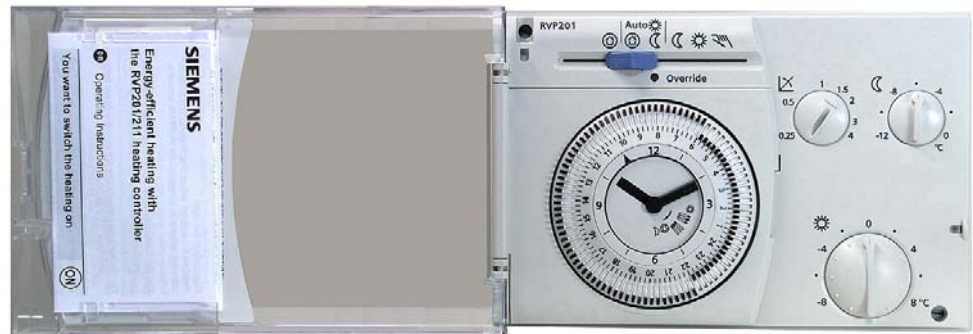

Controller RVP201 with 24-hour time switch AUZ3.1 (cover opened)

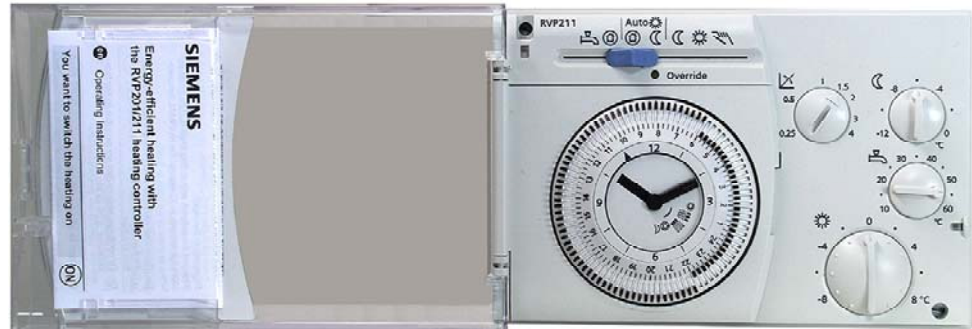

Controller RVP211 with 24-hour time switch AUZ3.1 (cover opened)

6.2 Time switches

6.2.1 General

The RVP201/211 has an opening for fitting a plug-in type time switch. If desired, the time switch fitted can be replaced by another type (refer to "1.2 Type summary"). The time switch is simply plugged in. The electrical connections to the controller are established via a terminal strip so that no wiring is required.

The following types of time switches are available:

- Analog 24-hour time switch AUZ3.1
- Analog weekly time switch AUZ3.7
- Digital weekly time switch AUD3

6.2.2 Analog time switches AUZ3...

Basic design

The analog time switches AUZ3.1 and AUZ3.7 are equipped with a quartz clock. Backup is 12 hours.

When power returns after a power failure, the clock will be readjusted. Automatic readjustment can be aborted by briefly setting the operating mode selector to manual operation  and then back to the required operating mode, allowing manual adjustment of the clock.

The switching dial has tappets that can be tilted. The heating periods are entered by tilting the tappets within the required period of time:

- Tappets tilted outward = normal temperature
- Tappets tilted inward = lower temperature (reduced or protection mode)

Analog 24-hour time switch AUZ3.1

The 24-hour time switch has a 24-hour switching dial. It carries 96 tappets, which means four tappets per hour, giving a resolution of 15 minutes. The shortest possible heating period also is 15 minutes.

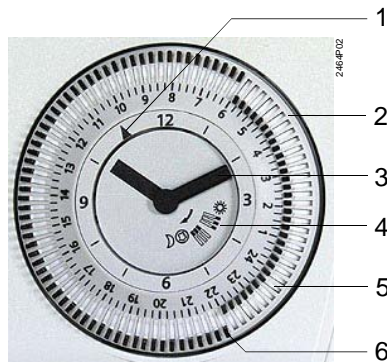

Front view of 24-hour time switch AUZ3.1 with a heating period from 6:00 to 22:00

- 1 Time indicator
- 2 Switching dial
- 3 Hand
- 4 Setting aid
- 5 Tappet tilted inward
- 6 Tappet tilted outward

Analog weekly time switch AUZ3.7

The weekly time switch has a 7-day switching dial. It carries 84 pairs of tappets, which means 12 pairs of tappets or 24 individual tappets per day. The resolution is thus one hour. However, since – for mechanical reasons – at least two tappets need to be tilted together to set one heating period, the shortest possible heating period is two hours.

6.2.3 Digital weekly time switch AUD3

The digital weekly time switch has an LCD and a number of buttons. Backup is ensured by a lithium battery

The AUD3 provides two setting and two operating modes (slide switch, see illustration below):

- Setting of time of day ⌚
- Setting of heating periods
- Automatic mode **Auto**
- Holiday mode . The holiday period that can be entered is either a maximum of 23 hours or a maximum of 27 days. Since the temperature level for the holiday period can be selected, this function affords programming of the operating modes "Normal" and "Setback" for a limited period of time

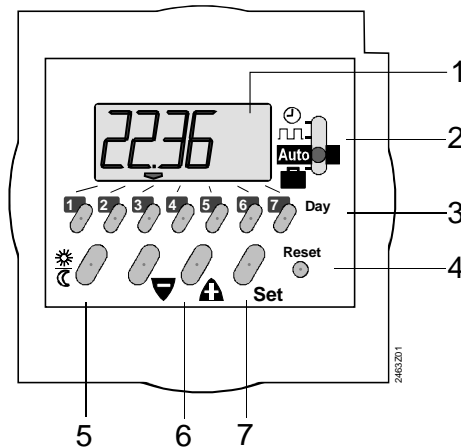

Front view of digital time switch AUD3

- 1 LCD
- 2 Slide switch for:
 - Setting the time of day
 - Setting the heating periods
 - Automatic mode
 - Holiday mode
- 3 Buttons for selecting the weekday
- 4 Reset button
- 5 Button for selecting the temperature level
- 6 Adjusting buttons:
 - Button to raise the displayed value
 - Button to lower the displayed value
- 7 Entry button

7 Technical data

Power supply	Rated operating voltage	AC 230 V ($\pm 10\%$)
	Frequency	50 Hz
	Power consumption (no external load)	7 VA
	Supply line fusing	10 A
Output relays	Switching capacity	AC 24...230 V, AC 0.02...2 (2) A
	Rated current of ignition transformer	max. 1 A (max. 30 s)
	Switch-on current of ignition transformer	max. 10 A (max. 10 ms)
Permissible cable lengths to the sensors and the room unit	Copper cable 0.6 mm \varnothing	30 m
	Copper cable 0.5 mm ²	50 m
	Copper cable 1.0 mm ²	80 m
	Copper cable 1.5 mm ²	120 m
Connection terminals	Screw terminals for wire section	up to 2.5 mm ²
Setting ranges	Setpoint of normal room temperature	20 \pm 0...8 °C
	Setback for reduced room temperature	-12...0 K
	Setpoint of d.h.w. temperature (only with the RVP211)	10...60 °C
	Slope of heating curve	0.25...4
	Max. limit of flow or boiler temperature	10...100 °C
	ECO heating limit	-10...+8 K (referred to normal setpoint)
	Authority of room temperature	0...100 %
	Switching differential with 2-position control	1...20 K
Backup of time switches	Analog time switches	12 hours
	Digital weekly time switch	with backup battery
Standards	CE -conformance to	
	EMC directive	2004/108/EC
	– Immunity	– EN 61000-6-1/2
	– Emissions	– EN 61000-6-3/4
	Low voltage directive	2006/95/EC
– Safety	– EN 60730-1 / EN 60730-2-9	
Protective data	Safety class	II to EN 60730
	Degree of protection (cover closed)	IP40 to EN 60529
	Degree of contamination	2 to EN 60730
Dimensions		refer to "Dimensions"
Weight	Unit (net)	0.72 kg
Colors	Controller insert	light grey RAL 7035
	Terminal base	pigeon blue RAL 5014

Environmental conditions

	<i>Operation</i> <i>EN 60721-3-3</i>	<i>Transport</i> <i>EN 60721-3-2</i>	<i>Storage</i> <i>EN 60721-3-1</i>
Climatic conditions	class 3K5	class 2K3	class 1K3
Temperature	0...+50 °C	-25...+70 °C	-20...+65 °C
Humidity	<95 % r.h. (non-condensing)	<95 % r.h.	<95 % r.h. (non-condensing)
Mechanical conditions	class 3M2	class 2M2	class 1M2
Use above sea level	max. 3000 m above sea level		

Index

2

24-hour time switch AUZ3.1 39

A

actual outside temperature 14, 23
amount of heat stored 22
analog time switches 38
application examples 10
attenuated outside temperature 14, 23
AUD3 digital weekly time switch 39
automatic 24-hour limit switch 23
automatic operation 12
automatic summer / winter switch 23
auxiliary terminals 34
AUZ3.1 24-hour time switch 39
AUZ3.7 weekly time switch 39

B

backup of time switches 40
basic setting heating curve 16
boost heating 21
building construction 14
building time constant 14, 23
burner cycling protection 20

C

change of flow temperature setpoint 16
coding switches 31, 32, 37
compensating variables 14
composite outside temperature 14, 23
connection diagrams 35
connection terminals 34

D

d.h.w. heating 12, 25
d.h.w. heating with changeover valve 26
d.h.w. heating with charging pump 25
d.h.w. priority 25
d.h.w. temperature 14
default value 32
development of outside temperature 15
deviation of room temperature 19
digital weekly time switch AUD3 39
dimensions 37
documentation 8

E

ECO automatic energy saver 22
ECO function 1 23
ECO function 2 23
economy button 28, 29
electric actuator 20
electric or electro-hydraulic actuators 20
electro-thermal actuators 20

enabling of d.h.w. heating 25
environmental conditions 41
external switch 13, 33, 35

F

factory settings 32
faults in the measuring circuits 13
features 7
field of use 9
fixing screw 37
frost protection for the boiler 20
frost protection for the building 24
frost protection for the d.h.w. storage tank 26
frost protection for the plant 24
frost protection mode 14

G

gain factor 15
generation of setpoint 17

H

handling of faults 13
heating curve 16
heating limit 23
heating periods 38
heating systems 9
holiday period 39

I

inadmissible room unit 28
influence of the room temperature 15
installation 33
installation instructions 8
interactions with room unit QAW50 28
interactions with room unit QAW70 29
intermediate relay 25
intermediate seasons 22

L

LED Override 31
limitations 21
lithium battery 39
low voltage connection diagrams 35
low voltage terminals 34

M

mains voltage connection diagrams 36
mains voltage terminals 34
manual operation 12, 26
maximum limitation of boiler temperature 21
maximum limitation of flow temperature 21
minimum limitation of boiler temperature 21
minimum running time of the burner 20
mounting 33
mounting methods 33

N		
normal mode	12	
O		
operating elements	37	
operating instructions	8	
operating mode buttons QAW70	29	
operating mode slider QAW50	28	
operating modes	12	
output relays	40	
outside temperature	13	
outside temperature	14	
override, LED	31	
P		
parallel displacement of the heating curve	19	
periodic pump run	27	
permissible cable lengths	40	
PI control	19	
point-to-point interface	13	
presence button	28, 29	
priority	25	
protection against discharging	26	
protection mode	12	
pump kick	27	
pump overrun	27	
Q		
QAW50 room unit	28	
QAW70 room unit	29	
quartz clock	38	
quick setback	22	
R		
readjust the room temperature	32	
reference room	19	
required operating mode	33	
resolution	39	
room authority	19	
room temperature	13	
		room temperature-compensated control
		room unit QAW50
		room unit QAW70
		room units
		S
		safety function
		sealed
		sensing element
		sensors flow or boiler temperature
		setback mode
		setpoint / actual value deviation of room temperature
		setpoint adjustments
		setting potentiometers
		setting ranges
		slope
		substitute line
		suitable actuators
		suitable room units
		suitable sensors
		summer / winter switch
		T
		tappets
		technical data
		thermostat
		three-position flow temperature control
		time switches
		two-position boiler temperature control
		two-position flow temperature control
		types of buildings
		types of sensors
		W
		weather-compensated control with room influence ..
		weekly time switch AUZ3.7

Siemens Switzerland Ltd
Building Technologies Group
International Headquarters
Gubelstrasse 22
CH-6301 Zug
Tel. +41 41 724 24 24
Fax +41 41 724 35 22

© 2007 Siemens Switzerland Ltd